

IMPLEMENTING MIDI ON SMSC SUPER I/O AND ULTRA I/O DEVICES

By Syed Amin

The Musical Instrument Digital Interface (MIDI), is a bi-directional serial asynchronous interface with a data transfer rate of 31.25 kbps ($\pm 1\%$). Developed in 1983, MIDI has become the de facto standard for interfacing computers to synthesizers, samplers, drum machines, mixing boards, special-effects processors, and other musical instruments. It is now found in every type of musical equipment from the least expensive keyboard to the most expensive digital multitrack recorder. MIDI-based application programs are available not just for recording and editing sound, but also for film and video production, and other such applications.

This application note describes how to implement the MIDI hardware interface on SMSC's Super I/O and Ultra I/O devices.

Note 1: The MIDI interface can be implemented on the following SMSC Super I/O and Ultra I/O devices:
FDC37C663, FDC37C664, FDC37C665/GT/LV/IR, FDC37C666/GT/LV/IR, FDC37C667,
FDC37C669, FDC37C9XX.

Note 2: In the schematics shown, the FDC37C665 device is used as an example. Schematics using other SMSC devices may have different pin numbers for the signals shown (Refer to Table 1 for a list of pin numbers on various SMSC devices).

1. The Hardware Schematic

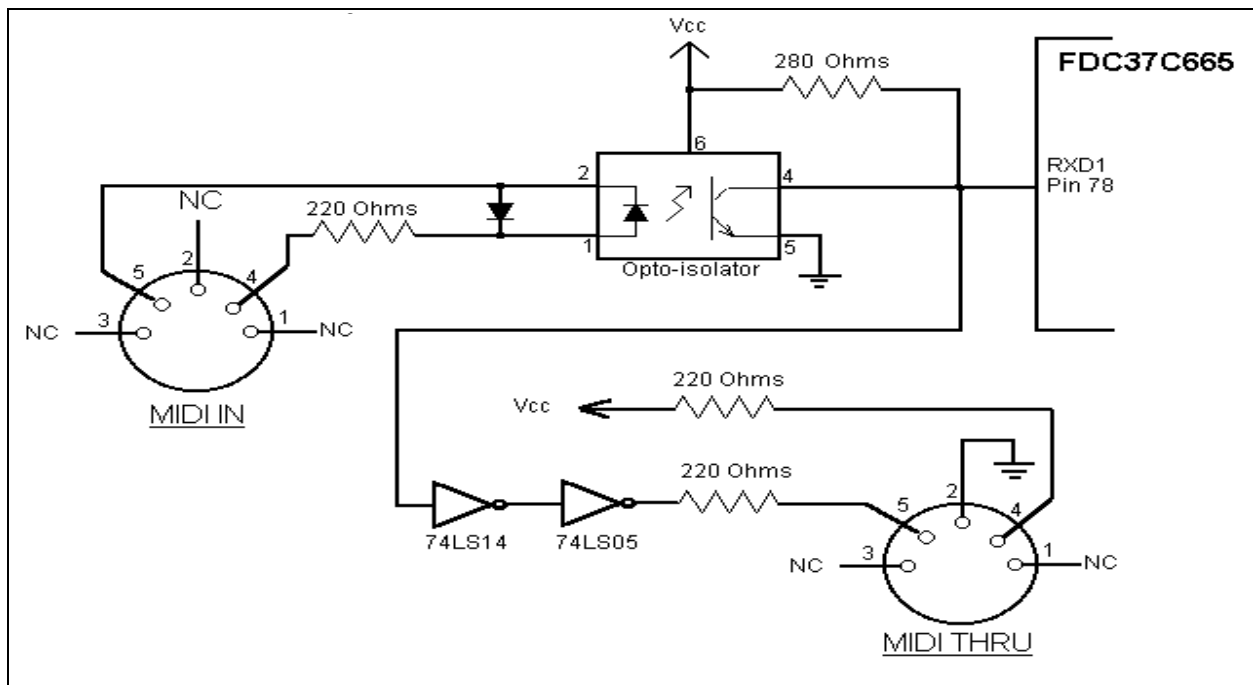

Figure 1 - Hardware schematic for the MIDI IN and MIDI THRU ports

Device	Serial Port 1		Serial Port 2	
	RXD1	TXD1	RXD2	TXD2
FDC37C663/664, FDC37C665/GT/LV/IR, FDC37C666/GT/LV/IR	78	79	88	89
FDC37C667	82	83	92	93
FDC37C669	78	79	88	89
FDC37C90X	88	89	25	26
FDC37C92X	124	125	135	137
FDC37C93X	145	146	155	156

Table 1 - Pin numbers for RXD and TXD signals on various SMSC devices

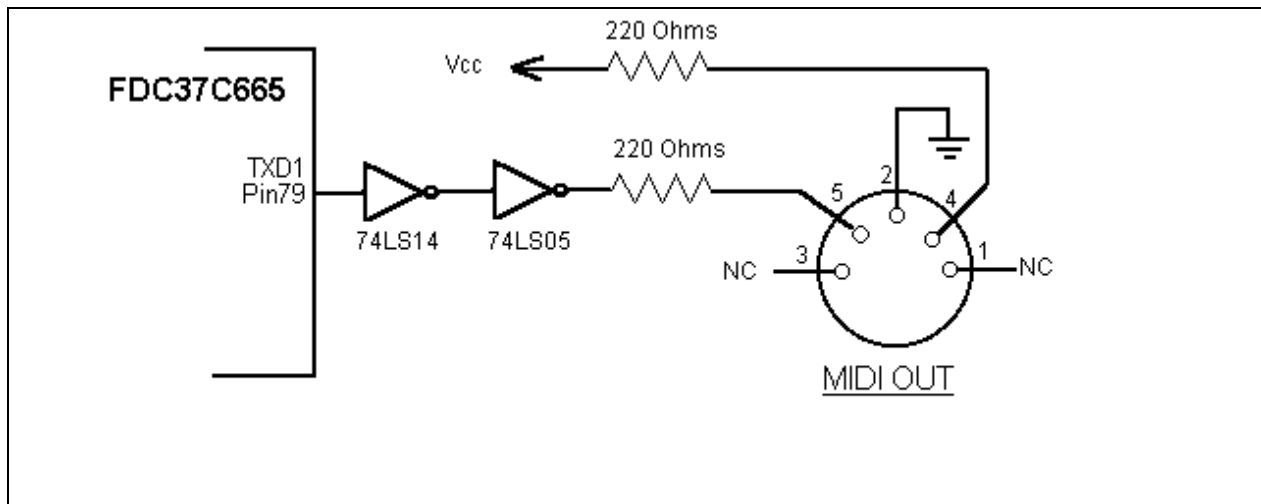

Figure 2 - Hardware schematic for the MIDI OUT port

Note 3: If the secondary serial port is to be used, RXD2 and TXD2 pins should be used instead of the RXD1 and TXD1 pins.

Note 4: The length of the MIDI cable should be no longer than 45 feet.

To be classified as a "MIDI-Compatible PC", a system must have at least two MIDI ports, MIDI IN and MIDI OUT. There is a third type of port, known as the MIDI THRU port, which is optional. The purpose of the MIDI THRU port is to retransmit the data that is received by the MIDI IN port. When more than two devices are to be connected, the MIDI THRU port is used for daisy-chaining these devices.

Note 5: Warning. Due to possible loss of signal quality, it is not advisable to daisy-chain more than three devices. To connect a larger number of devices, MIDI Mergers and MIDI THRU boxes should be used.

The connector that is used for all three of the MIDI ports is a 5-pin 180-degree DIN connector (e.g. the Switchcraft 57 GB5F). Pins 1 and 3 on this connector are not used. Pin 2 is the cable shield, and on the MIDI OUT and MIDI THRU ports, it should be connected to ground. On the MIDI IN port, pin 2 should not be connected to anything (to avoid ground loops). Pins 4 and 5 carry the 5 mA current loop that contains the data. This data is active low.

In order to isolate the MIDI data from electrical interference in the system, an optoelectrical isolator should be used at every MIDI IN port. The current-out to current-in ratio of this optoelectrical isolator should be 1:1, and it should have a response time of less than 2 microseconds. Examples of such optoelectric isolators are the Sharp PC-900, and the HP 6N138.

Since MIDI cables can be up to 45 feet in length, a 74LS14 and a 74LS05 are used to drive the data line, in order to make sure that the signal is a nice, clean square wave. The diode placed at the input of the optoelectrical isolator is to prevent the LED in the isolator from reverse polarization. The pair of 220 ohm resistors are used to regulate the current strength in the signal, and for protection against potential short-circuits.

2. Register Configurations

Note 6: The Register Configurations described below are for a 24 MHz crystal connected to the SMSC device. If a crystal with a different frequency is used, the registers should be programmed accordingly to obtain a data transfer rate of 31.25 kbps.

Configuring the FDC37C663/664/665(GT,LV,IR)/666(GT,LV,IR) devices:

- The UART to be used should be enabled and powered-on in Configuration Register 2.
- Bit 4 of Configuration Register 4 should be set to 1 (If the secondary serial port is to be used, Bit 5 should be set instead of Bit 4).
- A value of 04h should be placed in the divisor latch of the baud rate generator of the selected serial port.

Configuring the FDC37C669 device (for register and bit descriptions, refer to the data sheet):

- The UART to be used should be enabled and powered-on.
- Bit 3 of Configuration Register 2 should be set to 1 (For the second serial port, Bit 7 should be set to 1 instead of Bit 3).
- Bit 4 of Configuration Register 4 should be set to 1 (For the second serial port, Bit 5 should be set to 1 instead of Bit 4, and Bit 7 should be set to 0).
- Bit 6 of Configuration Register C should be set to 0 (For the second serial port, Bits 0, 1, 2, 3, 4, 5, and 7 should be set to 0).
- Bits 0, 1, 3, 4, 5, 6, and 7 of Configuration Register F should be set to 0 (Bit 2 should also be set to 0 if a 24 Mhz crystal is used).
- Bits 5 and 7 of Configuration Register 10 should be set to 0.
- Bit 0 of Configuration Register 11 should be set to 0.
- In Configuration Register 24, UART 1 should not be disabled (If the second serial port is being used, UART 2 should not be disabled in Configuration Register 25).

Configuring the FDC37C93X device:

- The serial port to be used (logical device # 4, or logical device # 5) should be activated.
- Power to the serial port should be turned on.
- The Base Address and the Hardware Interrupt Line should be selected.
- In the Mode Register, MIDI support should be enabled, and the High Speed option should be disabled.

- If the second serial port is being used, all bits in the IR Options Register should be set to 0.

Note 7: **FOR ALL DEVICES:** The character options in the Line Control Register of the selected serial port should be programmed as follows:

Character Length = 8 Bits, Number of Start Bits = 1, Number of Stop Bits = 1, Parity = disabled



80 Arkay Drive
Hauppauge, NY 11788
(631) 435-6000
FAX (631) 273-3123

Copyright © SMSC 2004. All rights reserved.

Circuit diagrams and other information relating to SMSC products are included as a means of illustrating typical applications. Consequently, complete information sufficient for construction purposes is not necessarily given. Although the information has been checked and is believed to be accurate, no responsibility is assumed for inaccuracies. SMSC reserves the right to make changes to specifications and product descriptions at any time without notice. Contact your local SMSC sales office to obtain the latest specifications before placing your product order. The provision of this information does not convey to the purchaser of the described semiconductor devices any licenses under any patent rights or other intellectual property rights of SMSC or others. All sales are expressly conditional on your agreement to the terms and conditions of the most recently dated version of SMSC's standard Terms of Sale Agreement dated before the date of your order (the "Terms of Sale Agreement"). The product may contain design defects or errors known as anomalies which may cause the product's functions to deviate from published specifications. Anomaly sheets are available upon request. SMSC products are not designed, intended, authorized or warranted for use in any life support or other application where product failure could cause or contribute to personal injury or severe property damage. Any and all such uses without prior written approval of an Officer of SMSC and further testing and/or modification will be fully at the risk of the customer. Copies of this document or other SMSC literature, as well as the Terms of Sale Agreement, may be obtained by visiting SMSC's website at <http://www.smsc.com>. SMSC is a registered trademark of Standard Microsystems Corporation ("SMSC"). Product names and company names are the trademarks of their respective holders.

SMSC DISCLAIMS AND EXCLUDES ANY AND ALL WARRANTIES, INCLUDING WITHOUT LIMITATION ANY AND ALL IMPLIED WARRANTIES OF MERCHANTABILITY, FITNESS FOR A PARTICULAR PURPOSE, TITLE, AND AGAINST INFRINGEMENT AND THE LIKE, AND ANY AND ALL WARRANTIES ARISING FROM ANY COURSE OF DEALING OR USAGE OF TRADE.

IN NO EVENT SHALL SMSC BE LIABLE FOR ANY DIRECT, INCIDENTAL, INDIRECT, SPECIAL, PUNITIVE, OR CONSEQUENTIAL DAMAGES; OR FOR LOST DATA, PROFITS, SAVINGS OR REVENUES OF ANY KIND; REGARDLESS OF THE FORM OF ACTION, WHETHER BASED ON CONTRACT; TORT; NEGLIGENCE OF SMSC OR OTHERS; STRICT LIABILITY; BREACH OF WARRANTY; OR OTHERWISE; WHETHER OR NOT ANY REMEDY OF BUYER IS HELD TO HAVE FAILED OF ITS ESSENTIAL PURPOSE, AND WHETHER OR NOT SMSC HAS BEEN ADVISED OF THE POSSIBILITY OF SUCH DAMAGES.