

LOW RTC CURRENT ALLOWS FOR THE REPLACEMENT OF THE BATTERY WITH A CAPACITOR IN FDC 37C9XX DEVICES

By Clemens Kaestner

SMSC has made a significant effort to improve the power consumption of the RTC in standby mode. The result is a specified typical standby current of 250 nA for the FDC37C93x family of Ultra I/O controllers. This Application note explains some alternatives to using a standard battery for providing power to the FDC37C93X in standby mode and therefore, reducing cost. The circuits shown are simply SPICE models and are shown as a guide. Engineers considering implementing these techniques should develop their own model using the electrical characteristics of the selected components.

1. Replacing the battery with a capacitor.

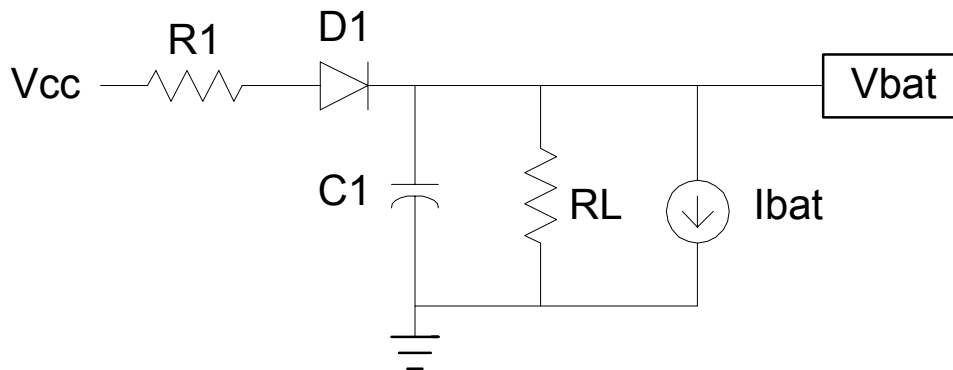

FIGURE 1 - SPICE MODEL FOR CAPACITOR STANDBY TIME

The schematic shows the model used for simulating a 93X backup circuit using a 1F capacitor to backup the RTC and CMOS Ram. The simulation gives us the expected supply time of the circuit powered by the capacitor load.

Note: RL simply simulates the leakage current of the capacitor and is not intended to be a part of the final ckt.

Note: V_{BAT} has to be in the range of $4.5V < V_{BAT} < V_{CC}-200mV$ or $2.4V < V_{BAT} < 4V$ in power on mode. If V_{BAT} is any greater that 200mv less than V_{CC} access to CMOS and the RTC will not be possible. V_{CC} has to be in the specified range.

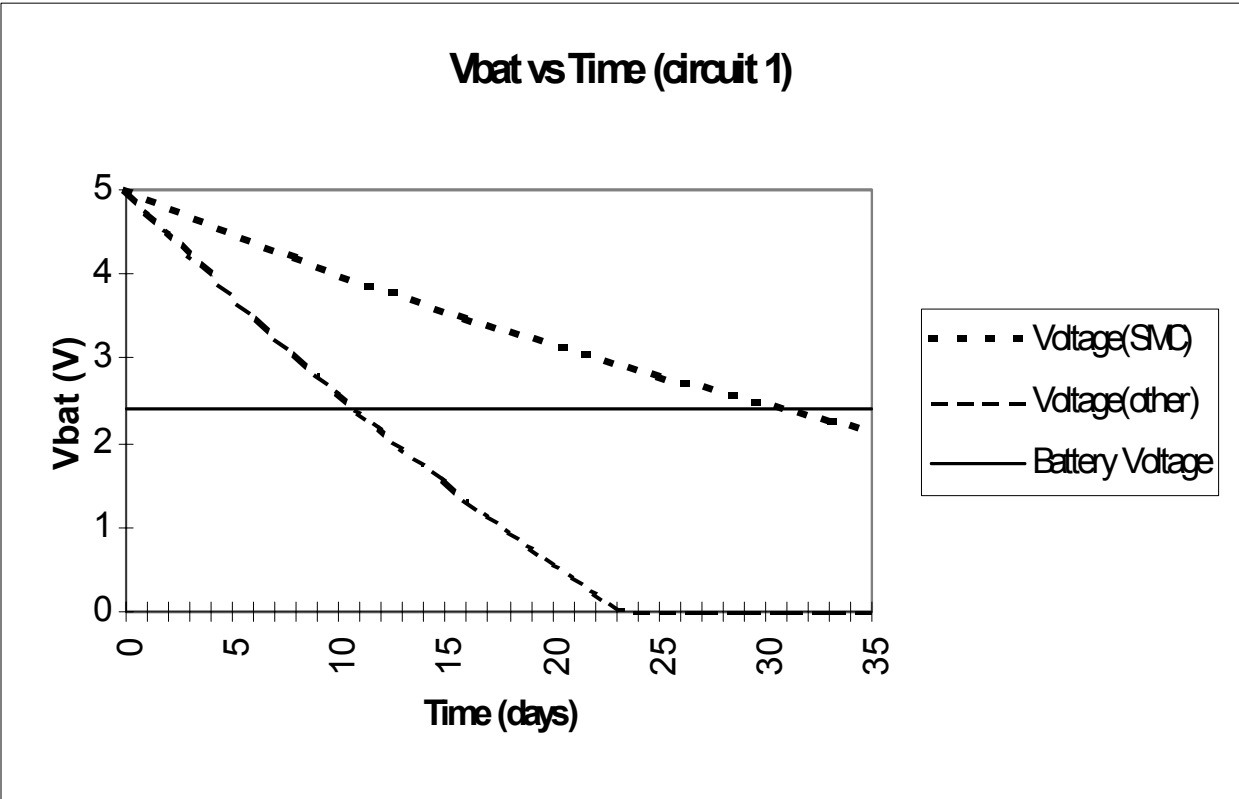

FIGURE 2 - Result of Simulation assuming that the capacitor was charged to 5V. Depending on diode selection, the capacitor will be charged to 4.3v - 4.7v.

As a result of the simulation we get a standby time for the capacitor of approximately 31 days. For systems with additional backup media for CMOS settings like an EEPROM connected to the 93X this should be more than sufficient.

The second trace shows an application with 2000 nA power consumption for a standard RTC. The Standby time for this configuration is just around 10 days. The SMSC FDC37C93X device improves the power consumption over standard devices by 8x to 250 nA.

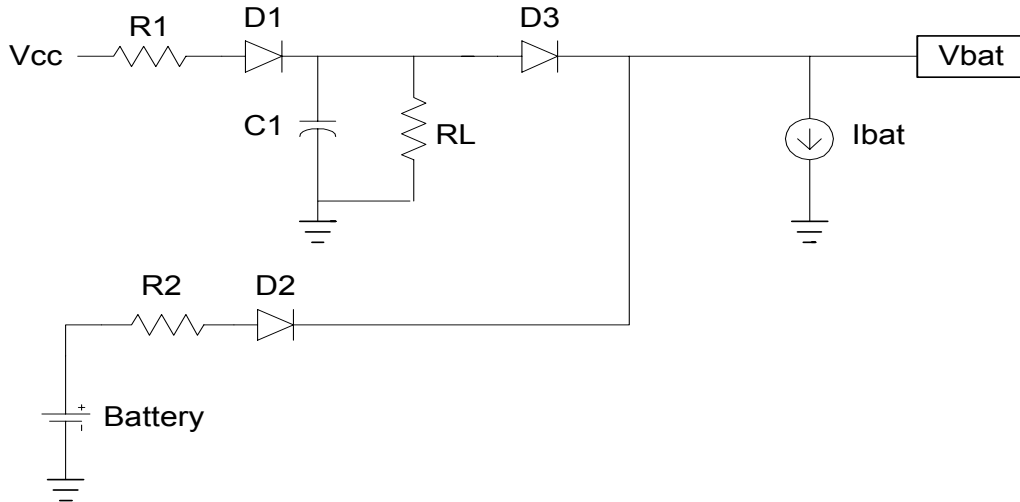

FIGURE 3 - SPICE MODEL FOR SMALL BATTERY PLUS CAPACITOR CIRCUIT SIMULATION

The schematic shows the model for simulating a FDC37C93X application using a 0.1F capacitor plus a small 3V battery to backup the RTC. Diode D3 isolates the battery from the leakage resistance of the supercap.

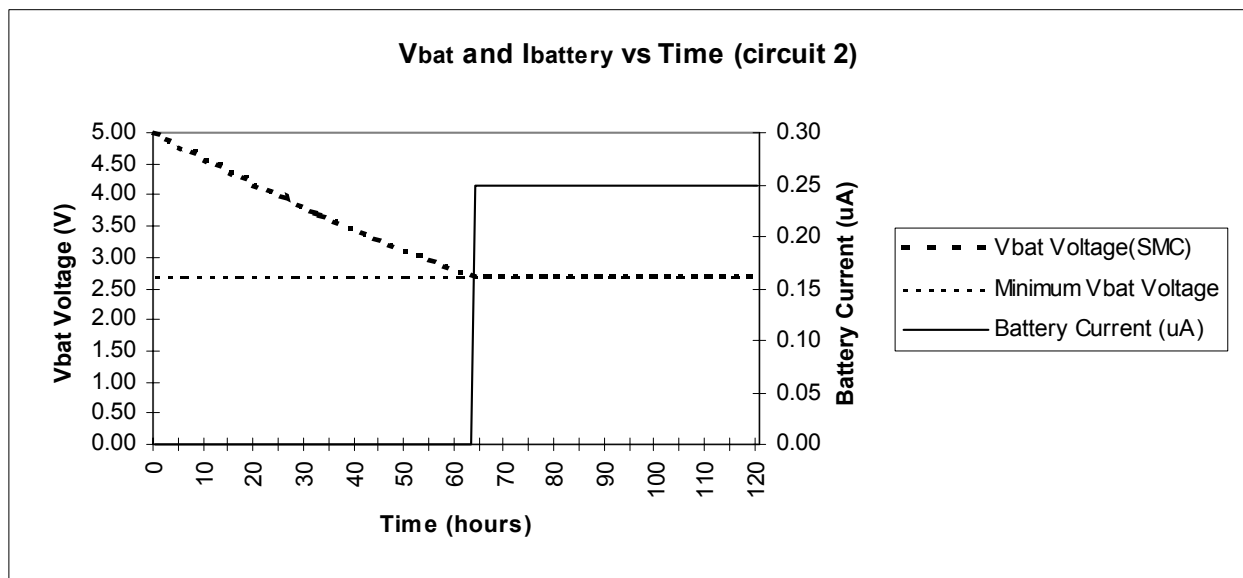

FIGURE 4 - RESULT OF THE SIMULATION

The simulation results show that during the first 223ksec (equal to 62 hours) after V_{CC} is switched off the battery is not discharged. In practice, this means that if a system is in daily use the battery current is always zero. This will expand the life time of even a small battery to several years and allow the battery change without losing the contents of the CMOS.



80 Arkay Drive
Hauppauge, NY 11788
(631) 435-6000
FAX (631) 273-3123

Copyright © SMSC 2004. All rights reserved.

Circuit diagrams and other information relating to SMSC products are included as a means of illustrating typical applications. Consequently, complete information sufficient for construction purposes is not necessarily given. Although the information has been checked and is believed to be accurate, no responsibility is assumed for inaccuracies. SMSC reserves the right to make changes to specifications and product descriptions at any time without notice. Contact your local SMSC sales office to obtain the latest specifications before placing your product order. The provision of this information does not convey to the purchaser of the described semiconductor devices any licenses under any patent rights or other intellectual property rights of SMSC or others. All sales are expressly conditional on your agreement to the terms and conditions of the most recently dated version of SMSC's standard Terms of Sale Agreement dated before the date of your order (the "Terms of Sale Agreement"). The product may contain design defects or errors known as anomalies which may cause the product's functions to deviate from published specifications. Anomaly sheets are available upon request. SMSC products are not designed, intended, authorized or warranted for use in any life support or other application where product failure could cause or contribute to personal injury or severe property damage. Any and all such uses without prior written approval of an Officer of SMSC and further testing and/or modification will be fully at the risk of the customer. Copies of this document or other SMSC literature, as well as the Terms of Sale Agreement, may be obtained by visiting SMSC's website at <http://www.smsc.com>. SMSC is a registered trademark of Standard Microsystems Corporation ("SMSC"). Product names and company names are the trademarks of their respective holders.

SMSC DISCLAIMS AND EXCLUDES ANY AND ALL WARRANTIES, INCLUDING WITHOUT LIMITATION ANY AND ALL IMPLIED WARRANTIES OF MERCHANTABILITY, FITNESS FOR A PARTICULAR PURPOSE, TITLE, AND AGAINST INFRINGEMENT AND THE LIKE, AND ANY AND ALL WARRANTIES ARISING FROM ANY COURSE OF DEALING OR USAGE OF TRADE.

IN NO EVENT SHALL SMSC BE LIABLE FOR ANY DIRECT, INCIDENTAL, INDIRECT, SPECIAL, PUNITIVE, OR CONSEQUENTIAL DAMAGES; OR FOR LOST DATA, PROFITS, SAVINGS OR REVENUES OF ANY KIND; REGARDLESS OF THE FORM OF ACTION, WHETHER BASED ON CONTRACT; TORT; NEGLIGENCE OF SMSC OR OTHERS; STRICT LIABILITY; BREACH OF WARRANTY; OR OTHERWISE; WHETHER OR NOT ANY REMEDY OF BUYER IS HELD TO HAVE FAILED OF ITS ESSENTIAL PURPOSE, AND WHETHER OR NOT SMSC HAS BEEN ADVISED OF THE POSSIBILITY OF SUCH DAMAGES.