

EMC140X/142X SMSC Evaluation Board

Design Details

Assemblies:
EVB-EMC140X/2X

Board:
PCB-EVB-7092 Rev A00
SMSC EVB 3.25" x 4.5"

Chips:
EMC1402, 1403, 1404, 1422, 1423, and 1424

Packages:
8-MSOP and 10-MSOP

Schematic Page Description	Page #
Title Page	1
EMC140X Devices	2
EMC142X Devices	3
USB to SMBus Bridge	4

Circuit diagrams utilizing SMSC Products are included as a means of illustrating typical semiconductor applications: Consequently complete information sufficient for construction purposes is not necessarily given. The information has been carefully checked and is believed to be entirely reliable. However, no responsibility is assumed for inaccuracies. Furthermore, such information does not convey to the purchaser of the semiconductor devices described any license under the patent rights of SMSC or others. SMSC reserves the right to make changes at any time in order to improve design and supply the best product possible.

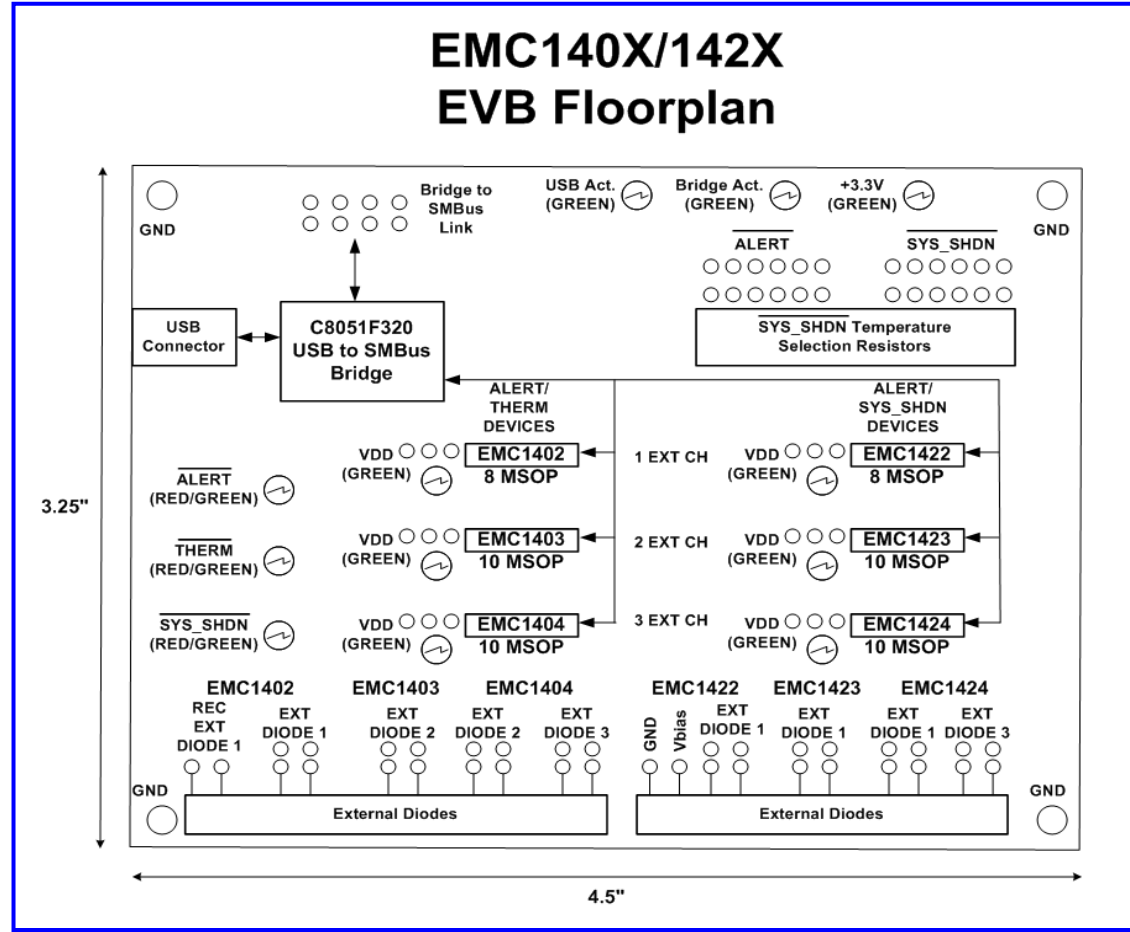

SMSC[™]
SUCCESS BY DESIGN

3930 East Ray Road
Suite 200
Phoenix, Arizona 85044
480-759-0200

Title EMC140X/142X EVB		
Size B	Document Number SCH-7092	Rev A0
Date: Monday, August 28, 2006	Sheet 1	of 4

EMC1402/03/04 ALERT/ and THERM/ pull-up resistors

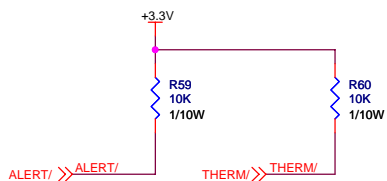

EMC1402 8-MSOP

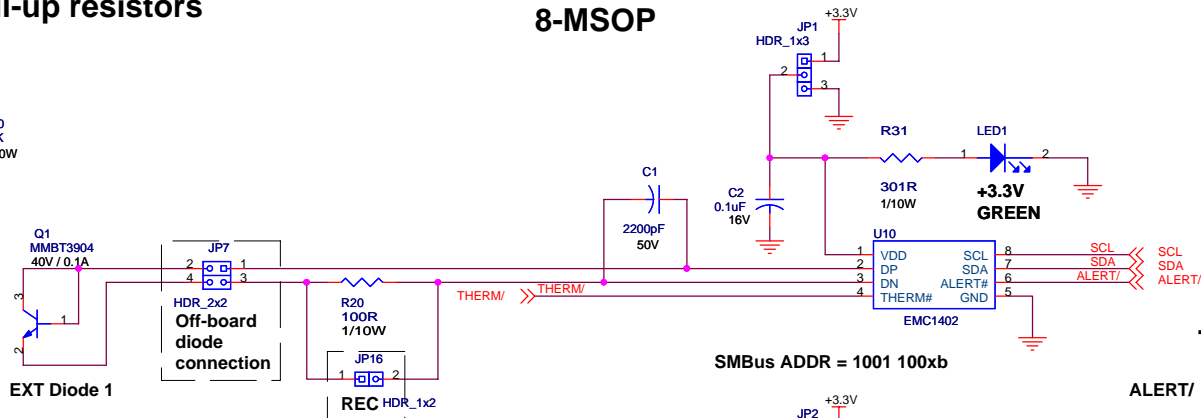

System Interrupt and LEDs

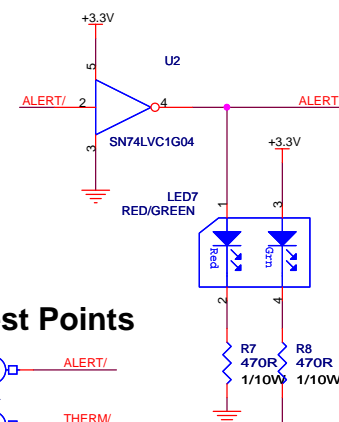

Test Points

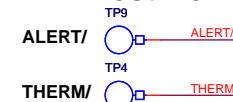

Power Test Points

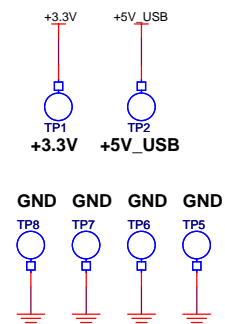

EMC1403 10-MSOP

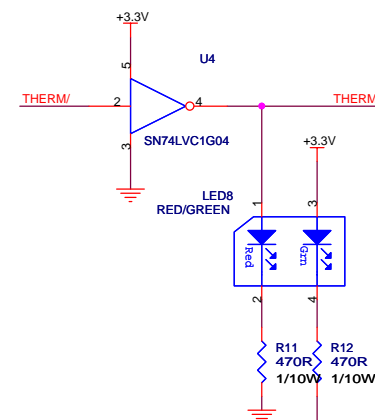
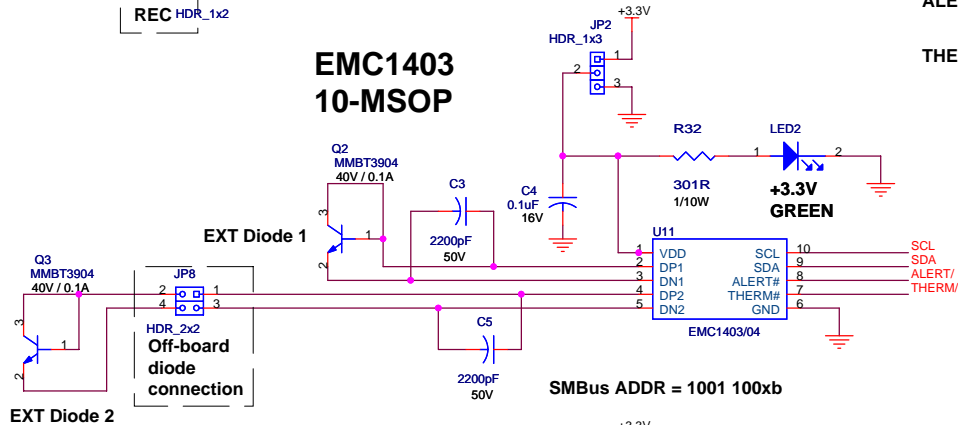

EMC1404 10-MSOP

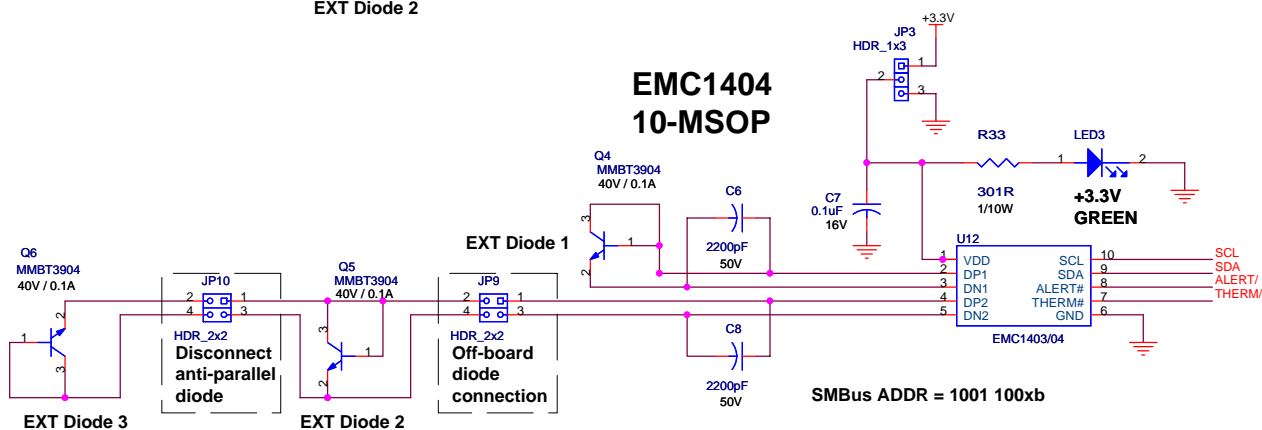



3930 East Ray Road
Suite 200
Phoenix, Arizona 85044
480-759-0200

Title: **EMC140X Devices**

Size B	Document Number SCH-7092	Rev A0
Date: Monday, August 28, 2006	Sheet 2 of 4	

EMC1422/23/24 ALERT/ and SYS_SHDN/ pull-up resistors

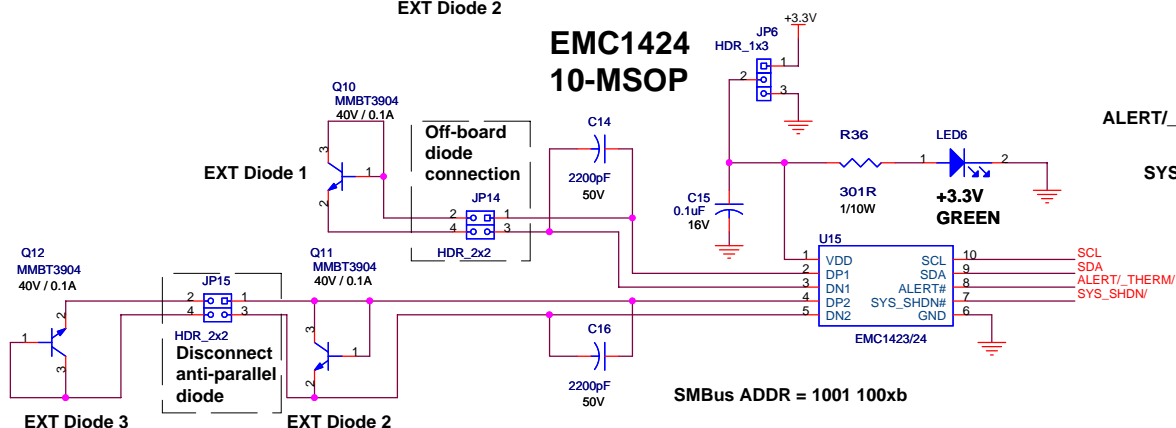
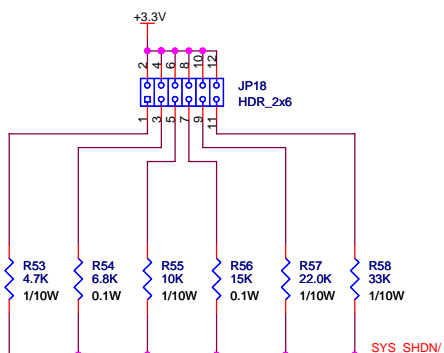
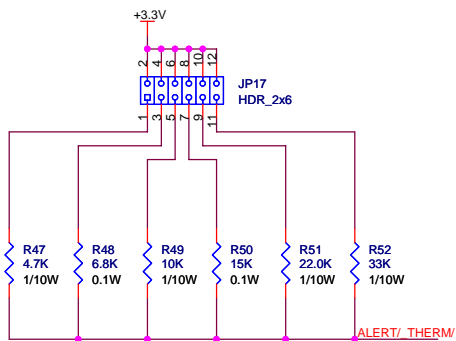

EMC1422 8-MSOP

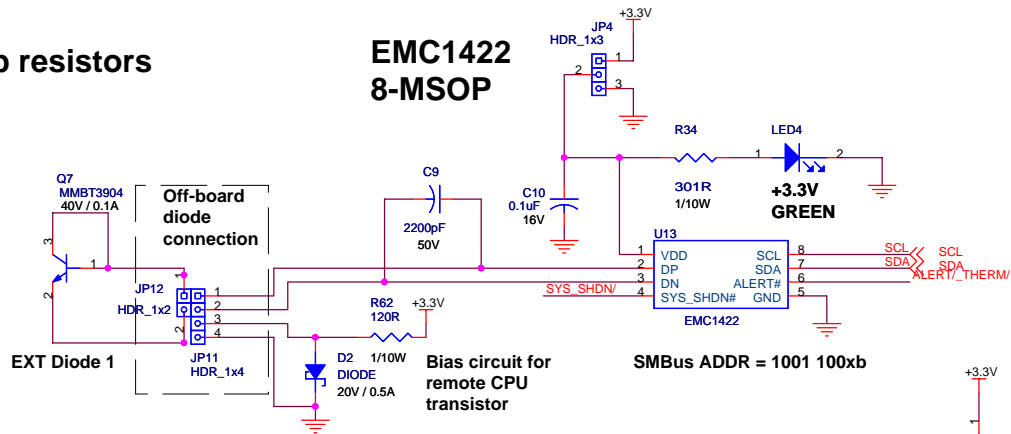

EMC1423 10-MSOP

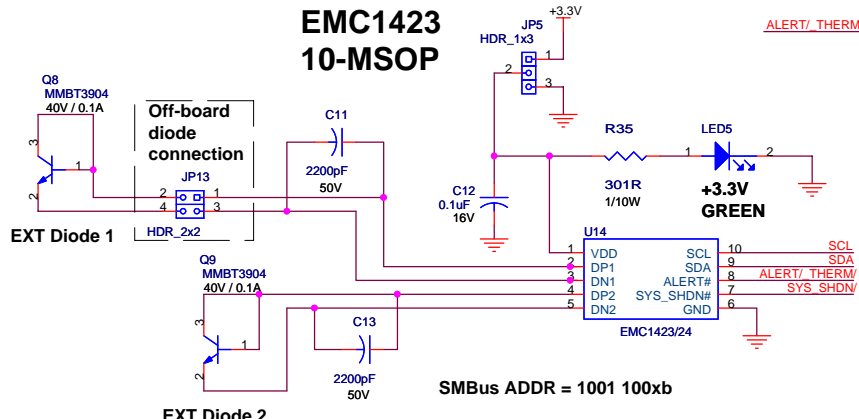

EMC1424 10-MSOP

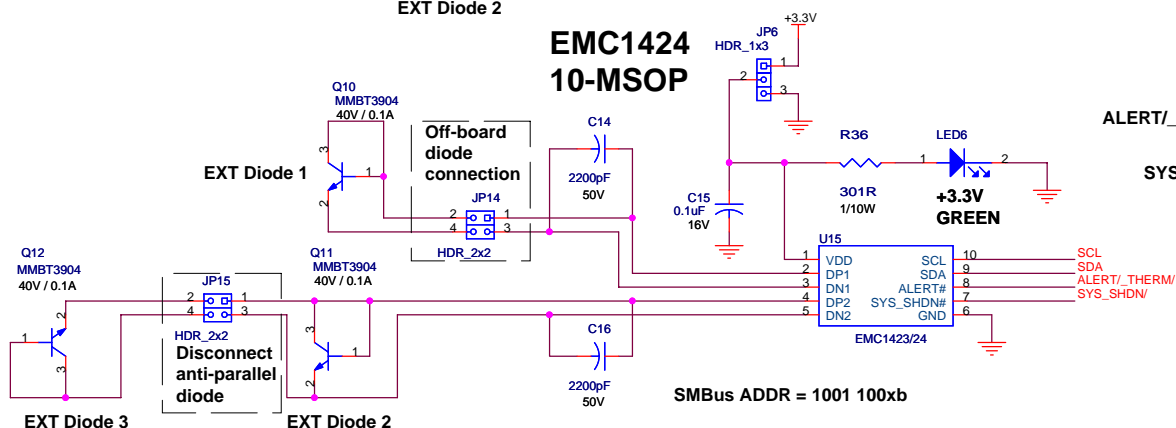

System Interrupt and LEDs

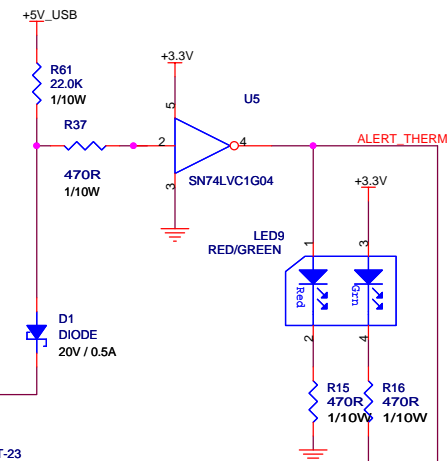

Test Points

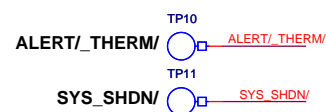

SMSC
SUCCESS BY DESIGN

3930 East Ray Road
Suite 200
Phoenix, Arizona 85044
480-759-0200

Title: **EMC142X Devices**

Size: B Document Number: **SCH-7092** Rev: **A0**

Date: Monday, August 28, 2006 Sheet 3 of 4

C8051F320 USB to SMBus Bridge

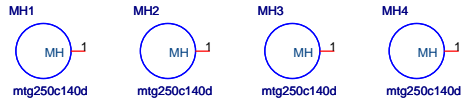
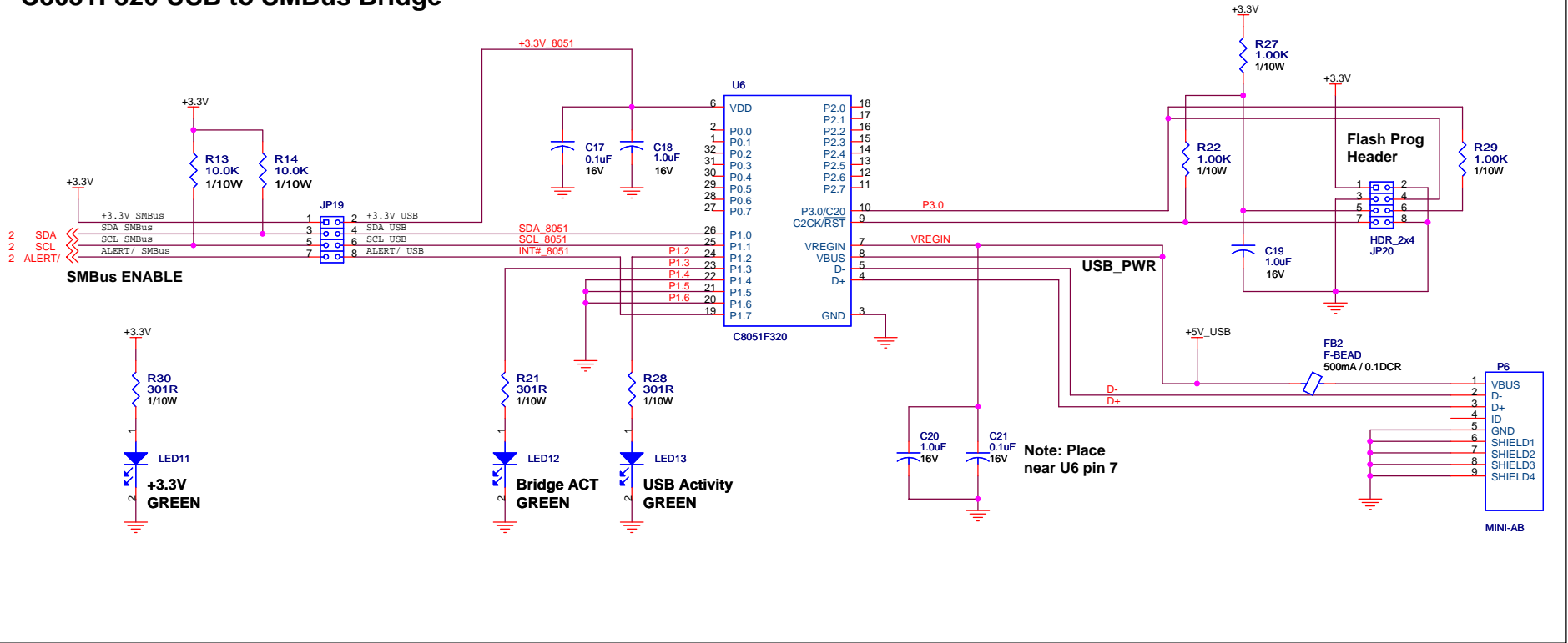

 SMSC SUCCESS BY DESIGN		3930 East Ray Road Suite 200 Phoenix, Arizona 85044 480-759-0200	
		Title USB to SMBus Bridge	
Size B	Document Number SCH-7092		Rev A0
Date:	Monday, August 28, 2006		Sheet 1 of 4