

SMSC LAN83C183 REFERENCE DESIGN ASSY 6116 REV B1 RELEASE

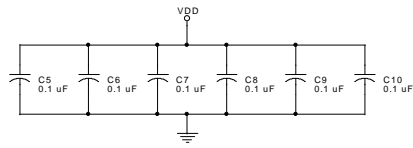
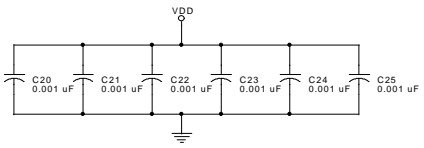
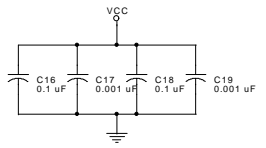
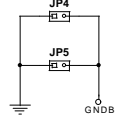
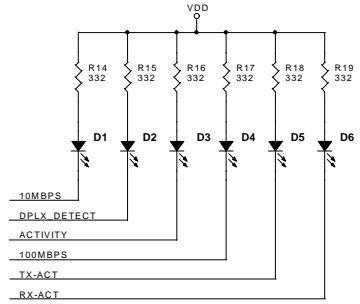
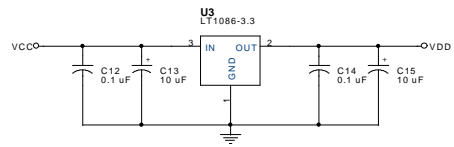
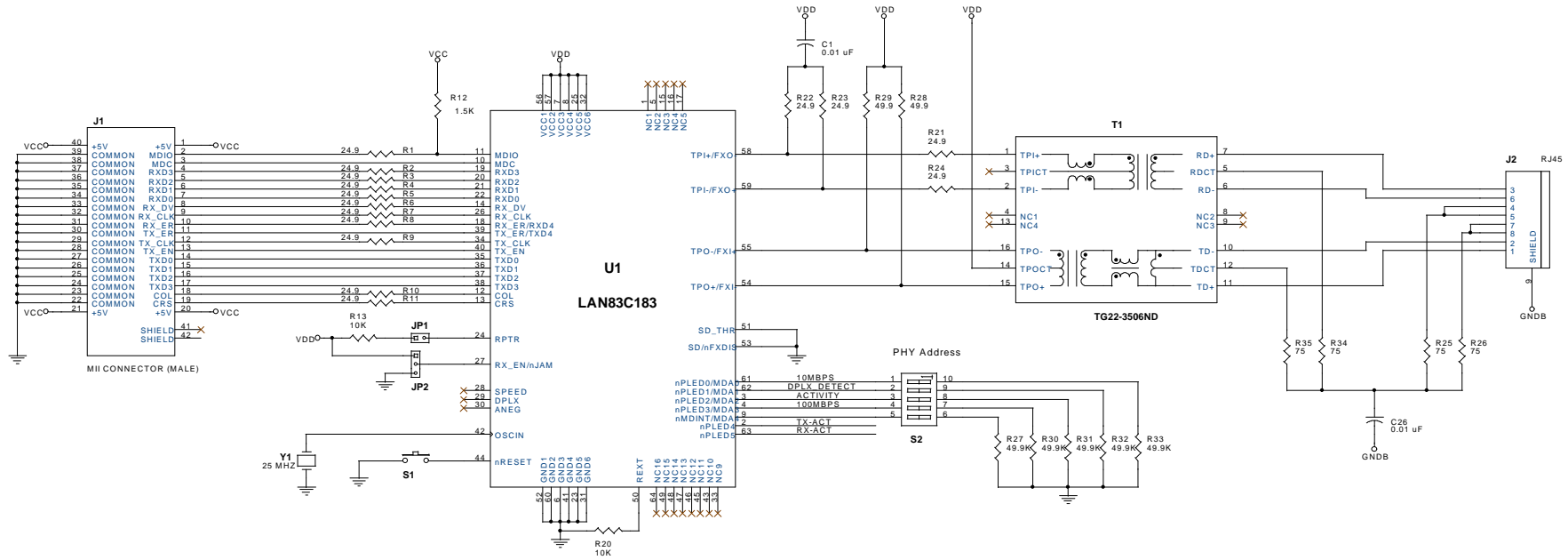

Circuit Diagrams utilizing SMSC Products are included as a means of illustrating typical semiconductor applications. Consequently complete information sufficient for construction purposes is not necessarily given. The information has been carefully checked and is intended to be entirely reliable. However, no responsibility is assumed for inaccuracies. Furthermore, such information does not convey to the purchaser of the semiconductor devices described any license under any patent rights of SMSC or others. SMSC reserves the right to make changes at any time in order to improve design and supply the best product possible.

STANDARD MICROSYSTEMS CORPORATION Engr.		
80 Arkay Drive P.O. Box 18047 Hauppauge, NY 11788-8847		
Title	LAN83C183	
Size	Document Number	Rev
C	6116	B1
Date:	Thursday, May 26, 2000	Sheet 1 of 1