

# EVB-LAN8700

## LAN8700(i) Reference Schematic

+3.3V I/O VDDIO Operation

MII Communication

Schematic Revision A0

### Design Details

Board:  
Chip: LAN8700(i)  
Board Form Factor:  
Assembly:

Circuit Diagrams utilizing SMSC Products Are Included As A Means Of Illustrating Typical Semiconductor Applications: Consequently Complete Information Sufficient For Construction Purposes Is Not Necessarily Given. The Information Has Been Carefully Checked And Is Believed To Be Entirely Reliable. However, No Responsibility Is Assumed For Inaccuracies. Furthermore, Such Information Does Not Convey To The Purchaser Of The Semiconductor Devices Described Any License Under The Patent Rights Of SMSC Or Others. SMSC Reserves The Right To Make Changes At Any Time In Order To Improve Design And Supply The Best Product Possible.

ITEM	Page
Title Page	1
LAN8700 & Magnetics	2

### EVB BLOCK DIAGRAM

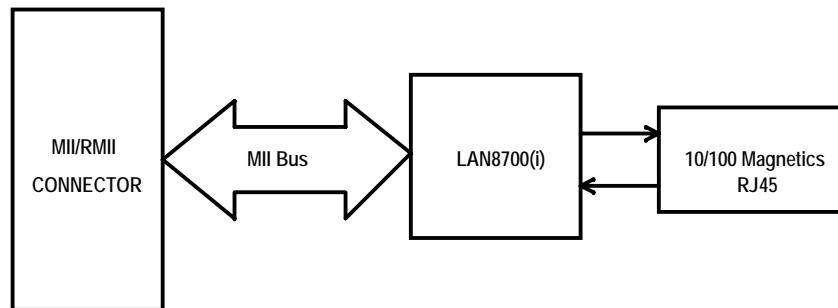

 <b>SMSC</b> <sup>®</sup> SUCCESS BY DESIGN		3930 East Ray Road Suite 200 Phoenix, Arizona 85044 480-759-0200
Title: LAN8700(i)		
Size: Custom	Document Number: <Doc>	Rev: <Rev>
Date: Monday, March 24, 2008		Sheet 1 of 2

## PHY Modes

(Default '111')

Mode 2 Mode 1 Mode 0

Empty	Empty	Empty	111	All Capable [Default]
Empty	Empty	10k to GND	110	Power Down Mode
Empty	10k to GND	Empty	101	Repeater Mode
Empty	10k to GND	10k to GND	100	100Base-TX Half duplex Advertised
10k to GND	Empty	Empty	011	100Base-TX Full Duplex Auto Negotiate
10k to GND	Empty	10k to GND	010	100Base-TX Half Duplex Auto Negotiate
10k to GND	10k to GND	Empty	001	10Base-T Full Duplex Auto Negotiate
10k to GND	10k to GND	10k to GND	000	10Base-T Half Duplex Auto Negotiate

## Variable IO

To use the variable I/O fleXPWR option connect pin 25 to the desired I/O. When using lower I/O voltages all pull-up resistors should be tied to this VDDIO supply. At low I/O voltage of 1.8V special LED considerations will need to be made.

## LEDs

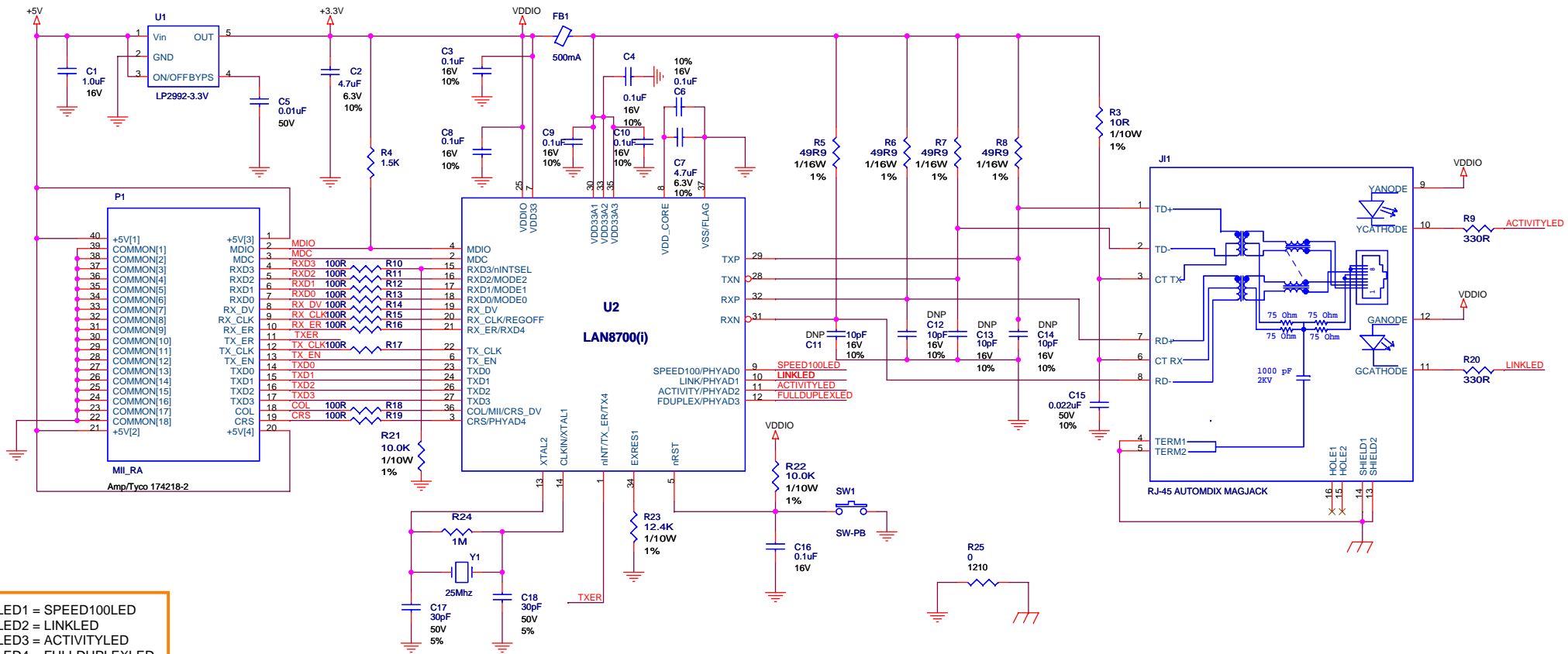
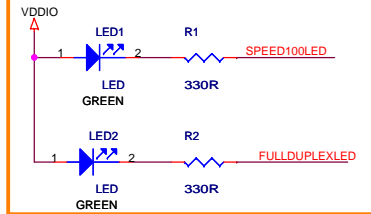

LED1 = SPEED100LED  
 LED2 = LINKLED  
 LED3 = ACTIVITYLED  
 LED4 = FULLDUPLEXLED

## PHY Address

(Default '11111' = 31d)

PHY Address LED Output Resistor configuration

LED	PHY Address	LED Output	Resistor configuration
LED1	LSB PHYAD0 = 1	Active Low	Default
	LSB PHYAD0 = 0	Active High	Populate 10k to GND on pin. Diode needs to be GND referenced
LED2	PHYAD1 = 1	Active Low	Default
	PHYAD1 = 0	Active High	Populate 10k to GND on pin. Diode needs to be GND referenced
LED3	PHYAD2 = 1	Active Low	Default
	PHYAD2 = 0	Active High	Populate 10k to GND on pin. Diode needs to be GND referenced
LED4	PHYAD3 = 1	Active Low	Default
	PHYAD3 = 0	Active High	Populate 10k to GND on pin. Diode needs to be GND referenced
	MSB PHYAD4 = 1		
	MSB PHYAD4 = 0		

## Integration Considerations:

- Prior to designing with LAN8700 please read SMSC LAN8700 User Guide and Configuration Application Note SMSC Magnetics Selection Guide AN8.13 SMSC LAN8700 Datasheet
- Please refer to our reference designs online for support during design. (<http://www.smSC.com/main/catalog/lan8700.html>)
- Once schematics are complete please submit to SMSC LANcheck for review: ([https://www2.smSC.com/mkt/web\\_lancheck.nsf](https://www2.smSC.com/mkt/web_lancheck.nsf))
- Once the layout is complete please submit to SMSC LANcheck for review: ([https://www2.smSC.com/mkt/web\\_lancheck.nsf](https://www2.smSC.com/mkt/web_lancheck.nsf))

\* Note: The (i) designates industrial temperature LAN8700i PHY (-40c to +85c). For industrial temperature applications, SMSC recommends using the LAN8700i with industrial temperature magnetics. Please refer to APP note 8.13 Magnetics Selection Guide".



**SMSC**  
SUCCESS BY DESIGN

3930 East Ray Road  
Suite 200  
Phoenix, Arizona 85044  
480-759-0200

Title: LAN8700(i)			
Size: Custom<Doc>	Document Number:	Rev: <Rev Code>	
Date: Monday, March 24, 2008	Sheet: 2	of: 2	