

SMSC LPC47B37X REFERENCE DESIGN ASSY 6113 REV A1

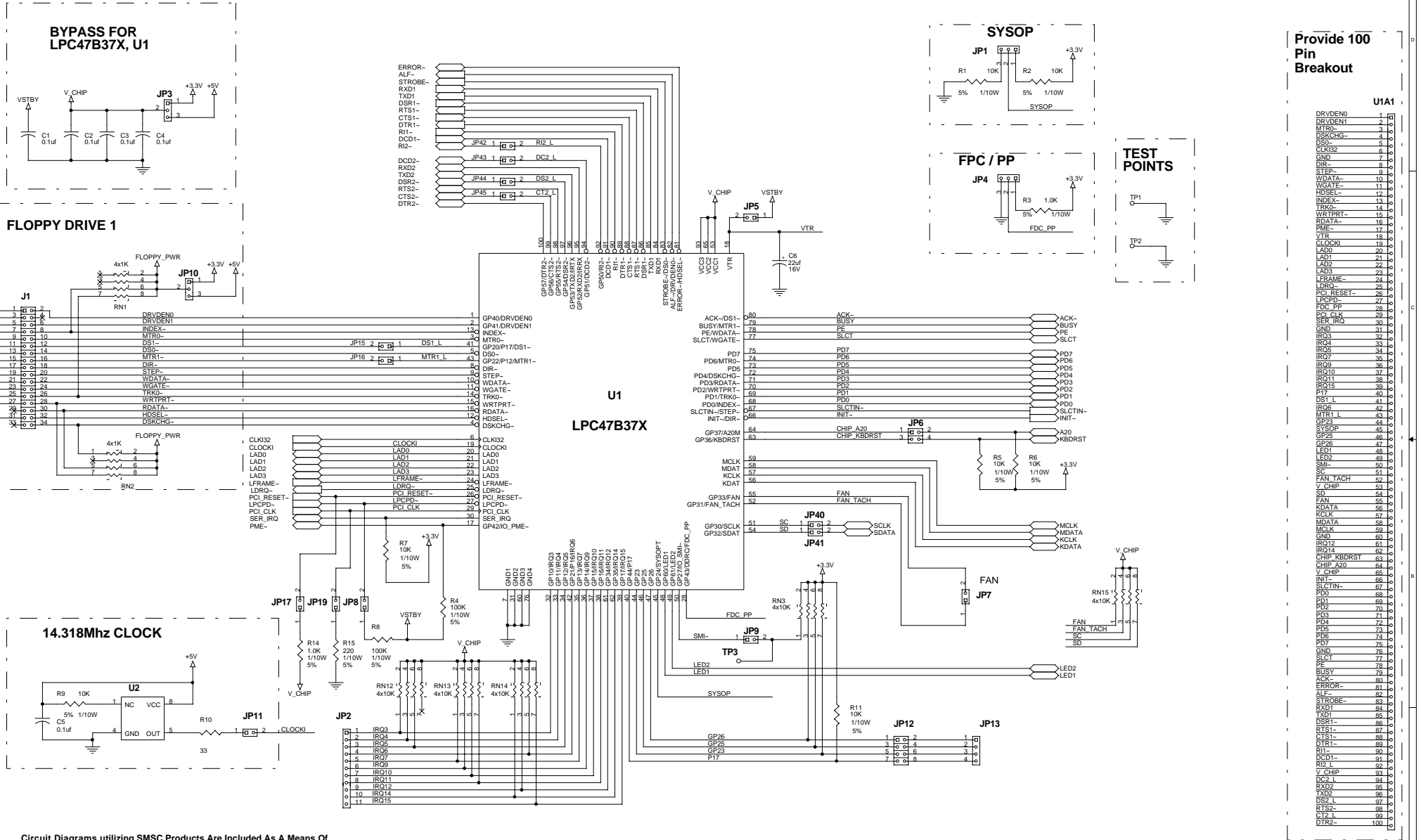

Circuit Diagrams utilizing SMSC Products Are Included As A Means Of Illustrating Typical Semiconductor Applications; Consequently Complete Information Sufficient For Construction Purposes Is Not Necessarily Given. The Information Has Been Carefully Checked And Is Believed To Be Entirely Reliable. However, No Responsibility Is Assumed For Inaccuracies. Furthermore, Such Information Does Not Convey To The Purchaser Of The Semiconductor Devices Described Any License Under The Patent Rights Of SMSC Or Others. SMSC Reserves The Right To Make Changes At Any Time In Order To Improve Design And Supply The Best Product Possible.

STANDARD MICROSYSTEMS CORPORATION		Engr. J. Minahan
80 Arkay Drive P.O. Box 18047 Hauppauge, NY 11788-8847		
Title: LPC47B37X		
Size: C	Document Number: 6113	Rev: A1
Date: Thursday, October 29, 1998 Sheet 1 of 3		

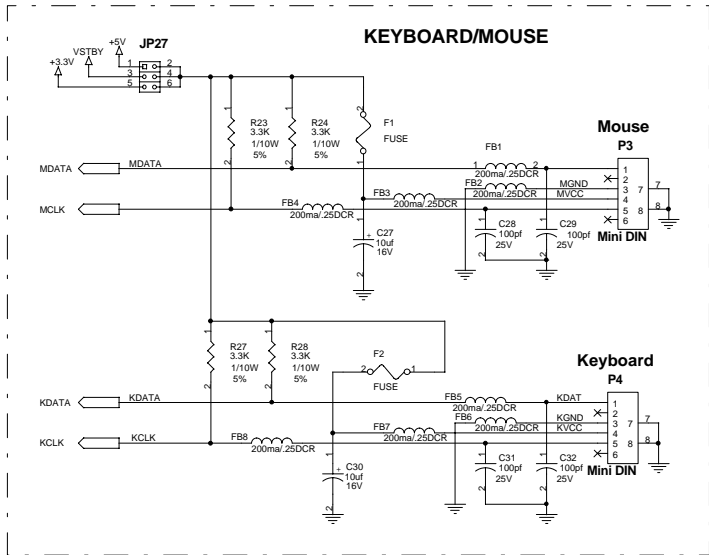
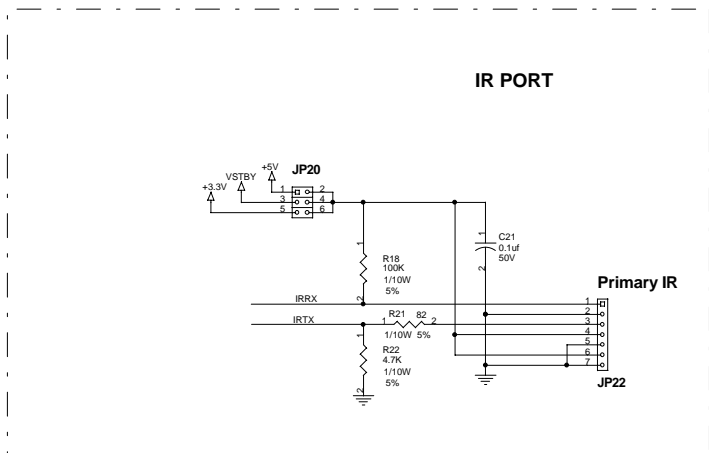
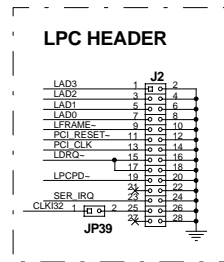
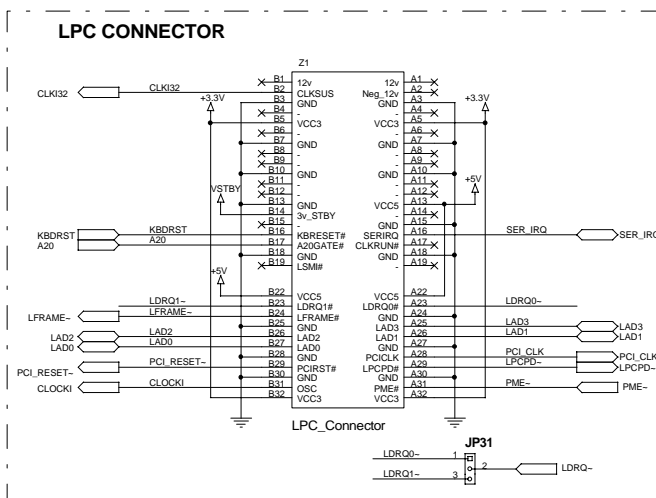
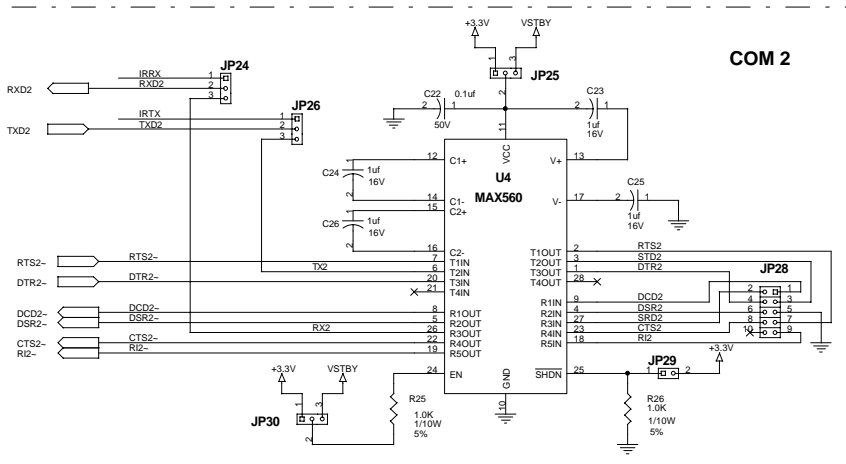
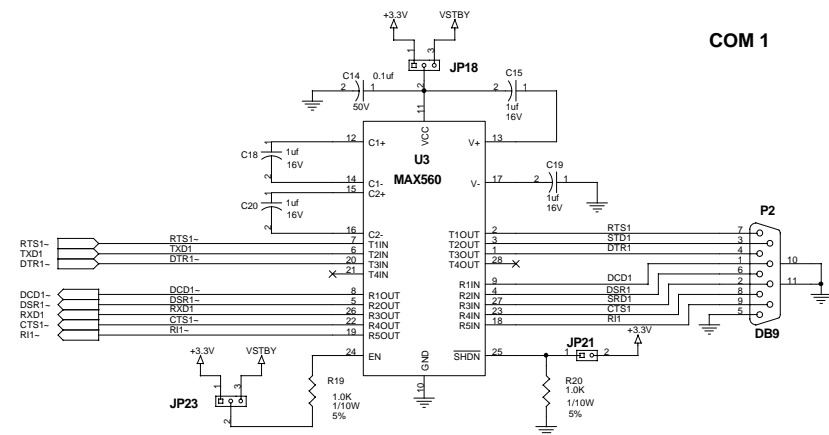

Circuit Diagrams utilizing SMSC Products Are Included As A Means Of Illustrating Typical Semiconductor Applications; Consequently Complete Information Sufficient For Construction Purposes Is Not Necessarily Given. The Information Has Been Carefully Checked And Is Believed To Be Entirely Reliable. However, No Responsibility Is Assumed For Inaccuracies. Furthermore, Such Information Does Not Convey To The Purchaser Of The Semiconductor Devices Described Any License Under The Patent Rights Of SMSC Or Others. SMSC Reserves The Right To Make Changes At Any Time In Order To Improve Design And Supply The Best Product Possible.

STANDARD MICROSYSTEMS CORPORATION		Engr. J.Minakian
80 Arkay Drive P.O. Box 18047 Hauppauge, NY 11788-8847		
TITLE: LPC47B37X		
Size	Document Number	Rev
C	6113	A1
Date:	Thursday, October 29, 1998	Sheet 2 of 3

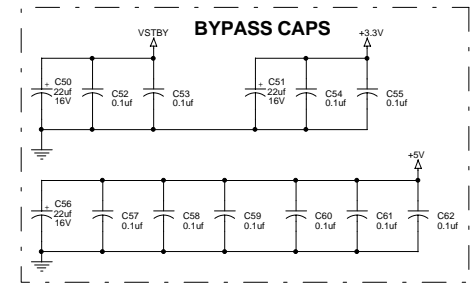
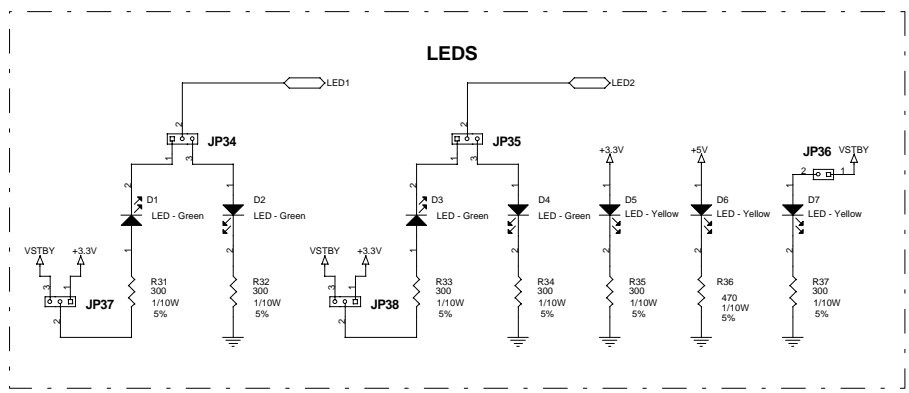
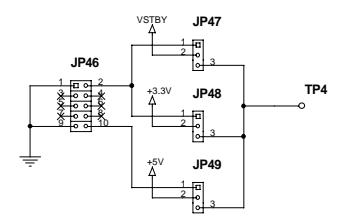
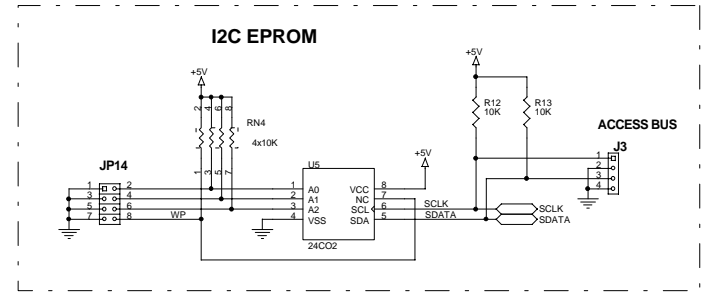
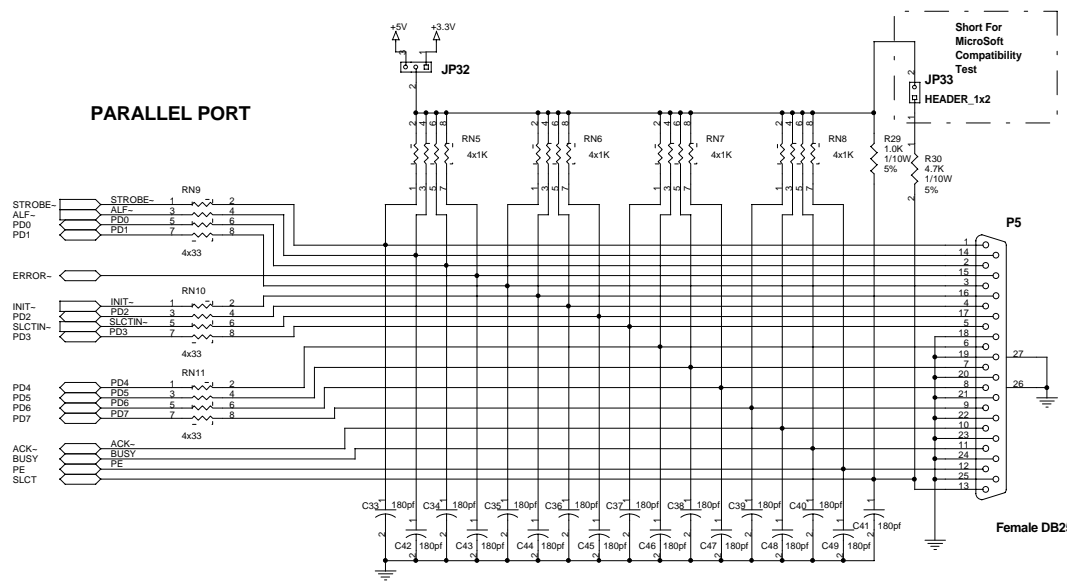

Circuit Diagrams utilizing SMSC Products Are Included As A Means Of Illustrating Typical Semiconductor Applications: Consequently Complete Information Sufficient For Construction Purposes Is Not Necessarily Given. The Information Has Been Carefully Checked And Is Believed To Be Entirely Reliable. However, No Responsibility Is Assumed For Inaccuracies. Furthermore, Such Information Does Not Convey To The Purchaser Of The Semiconductor Devices Described Any License Under The Patent Rights Of SMSC Or Others. SMSC Reserves The Right To Make Changes At Any Time In Order To Improve Design And Supply The Best Product Possible.

STANDARD MICROSYSTEMS CORPORATION		Engr. J. Minahan
80 Arkay Drive P.O. Box 18047 Hauppauge, NY 11788-8847		
Title: LPC47B37X		
Size: C	Document Number: 6113	Rev: A1
Date: Friday, November 13, 1998	Sheet: 3 of 3	