

LAN9311 Reference Design

Schematic Revision 0.3

ITEM	Page
Title Page	1
LAN9311	2
Ethernet Ports	3

Circuit diagrams utilizing SMSC products are included as a means of illustrating typical semiconductor applications; consequently complete information sufficient for construction purposes is not necessarily given. The information has been carefully checked and is believed to be entirely reliable. However, no responsibility is assumed for inaccuracies. Furthermore, such information does not convey to the purchaser of the semiconductor devices described any license under the patent rights of SMSC or others. SMSC reserves the right to make changes at any time in order to improve design and supply the best product possible.

			
Title Title Page			
Size C	Engineer R. Walsh	Assembly No. N/A	Rev 0.3
Date: Thursday, January 03, 2008		Sheet 1 of 3	

NOTE:
 FIFO_SEL and END_SEL can be driven dynamically and are not pulled internally to either state.
 FIFO_SEL and END_SEL have the same timing as the Address Bus and can be driven by upper address bits not used by the LAN9311. Refer to datasheet.

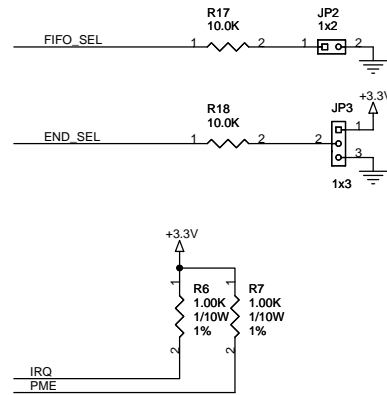

NOTE:
 LED_EN, PHY_ADDR_SEL, AUTO_MDIX_1&2 configuration straps are pulled up internally and are latched on power-up or on the rising edge of nRST..

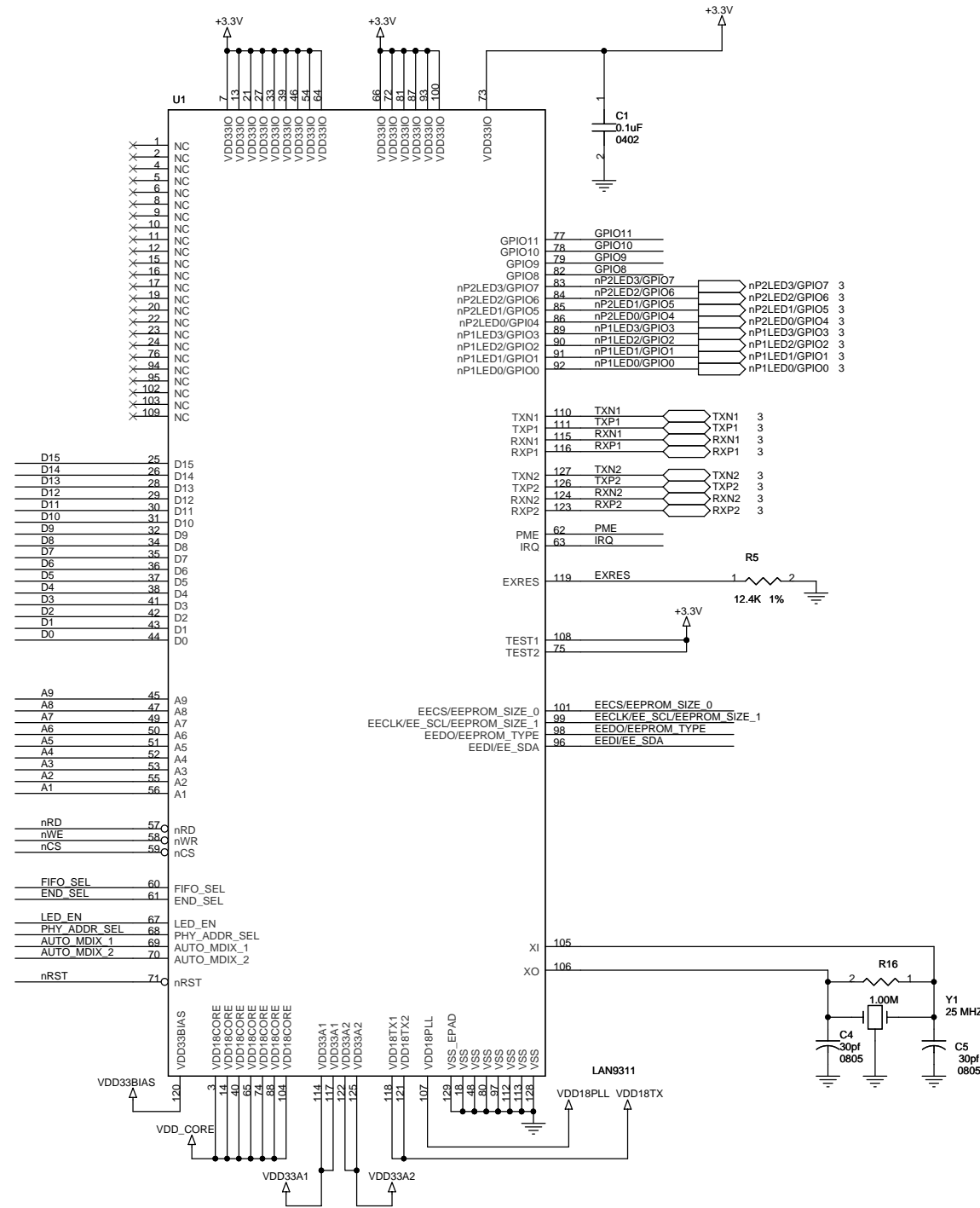
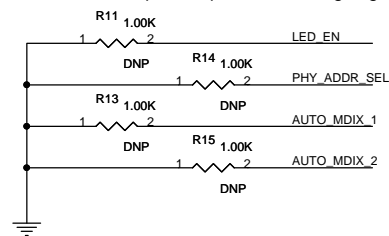

Optional Microwire/I2C Serial EEPROM

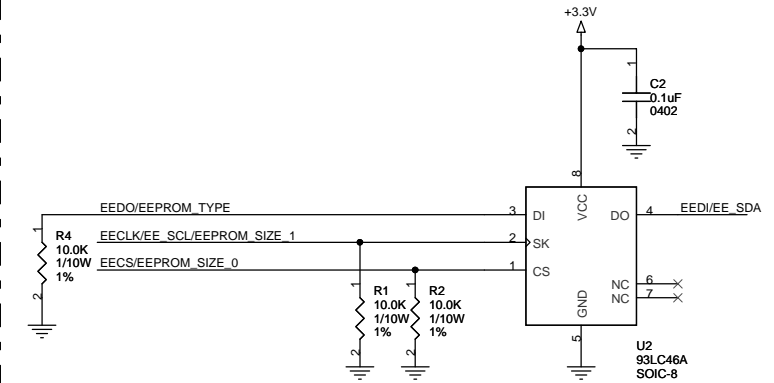

NOTE:
 R4 configures LAN9311 for uWire EEPROM type.
 R1 and R2 set EEPROM size.

NOTE:
 Use of external EEPROM's is optional. Populate one or the other, but not both.

Optional I2C Serial EEPROM

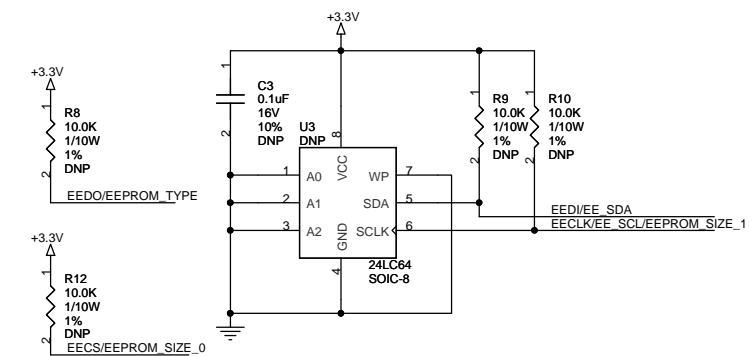

NOTE:
 R8 configures LAN9311 for I2C EEPROM type.
 R12 sets EEPROM size.

LAN9311 Filtering and Decoupling Capacitors

NOTE:
 Place bulk capacitors as close as possible to pins of LAN9311 as follows:
 C38 U1-120
 C21 U1-93
 C22 U1-74 (LOW ESR ONLY)
 C30 U1-117
 C32 U1-125
 C37 U1-121 (LOW ESR ONLY)
 C34 U1-107

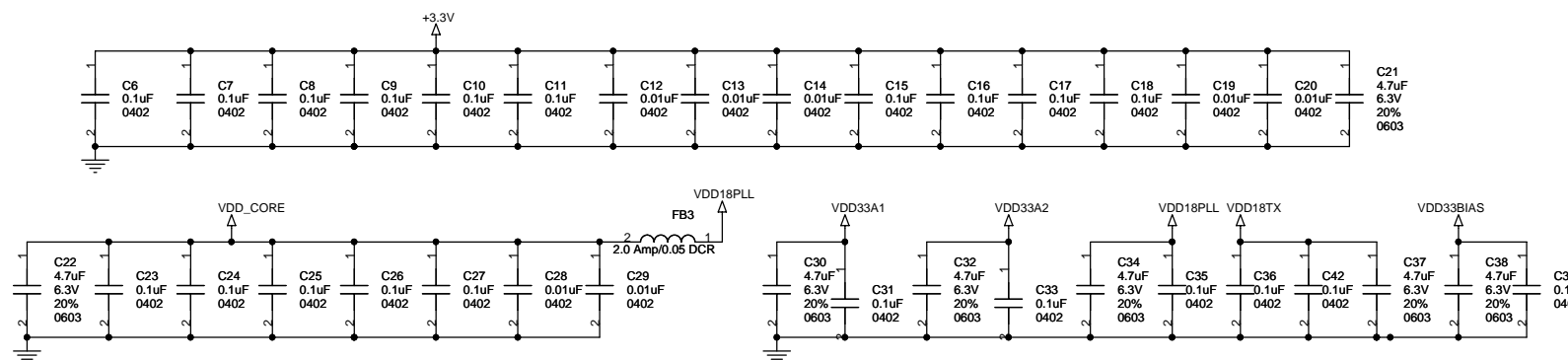
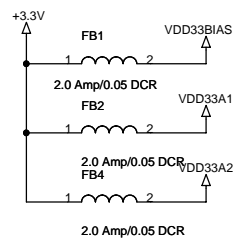

Title LAN9311			
Size C	Engineer R. Walsh	Assembly No. N/A	Rev 0.3
Date: Thursday, January 03, 2008		Sheet 2 of 3	

NOTE:
Place 49.9 ohm pull-ups close to LAN9311. Place 10 ohm CT resistor close to transformer.

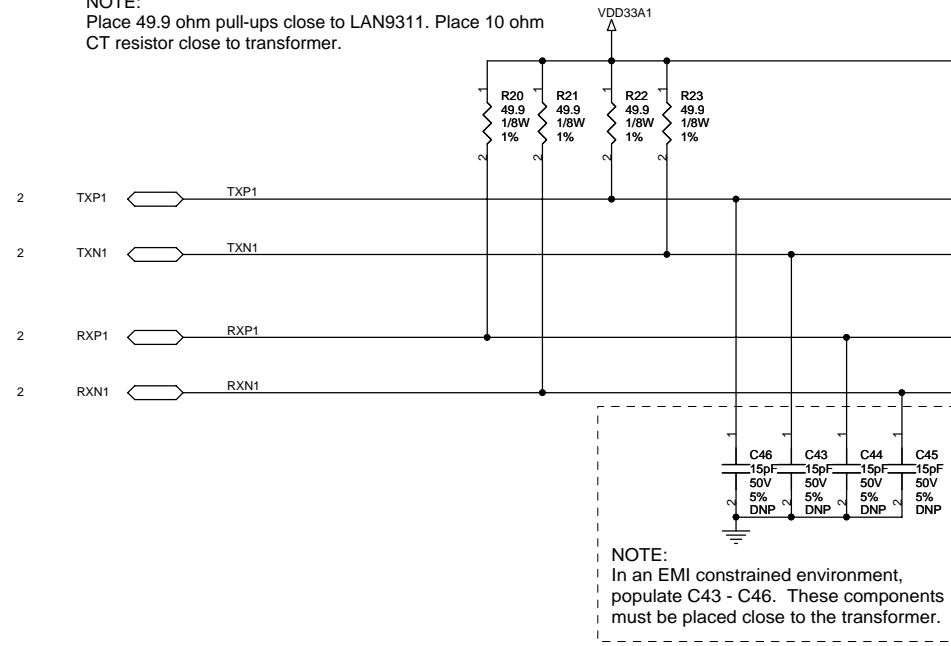

NOTE:
In an EMI constrained environment, populate C43 - C46. These components must be placed close to the transformer.

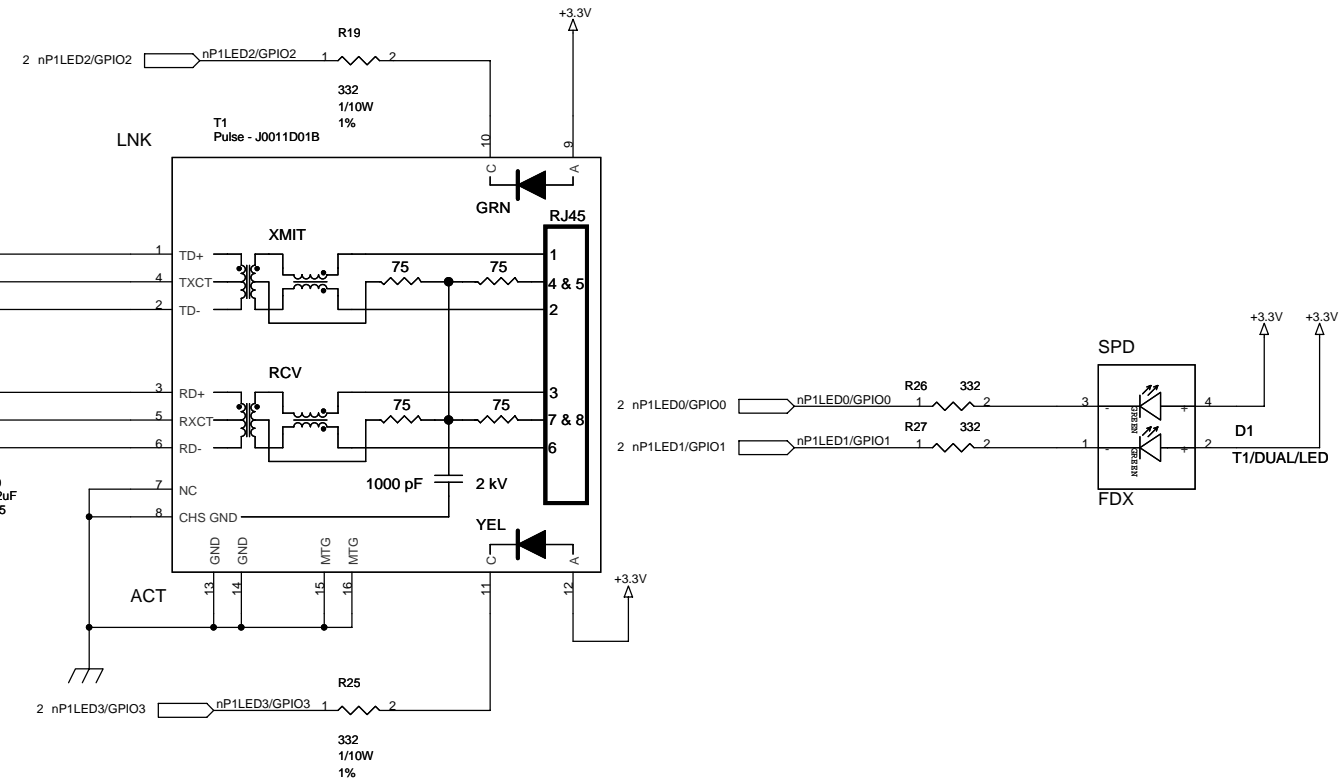

NOTE:
Place 49.9 ohm pull-ups close to LAN9311. Place 10 ohm CT resistor close to transformer.

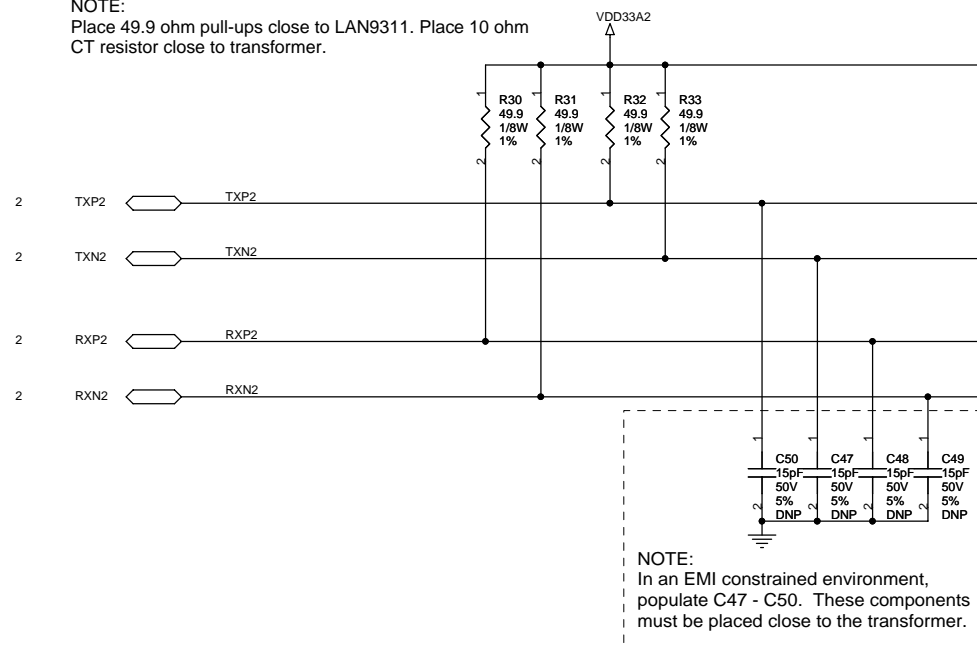

NOTE:
In an EMI constrained environment, populate C47 - C50. These components must be placed close to the transformer.

