

EVB-USB2250

EVB USB2250, 128 pin QFP

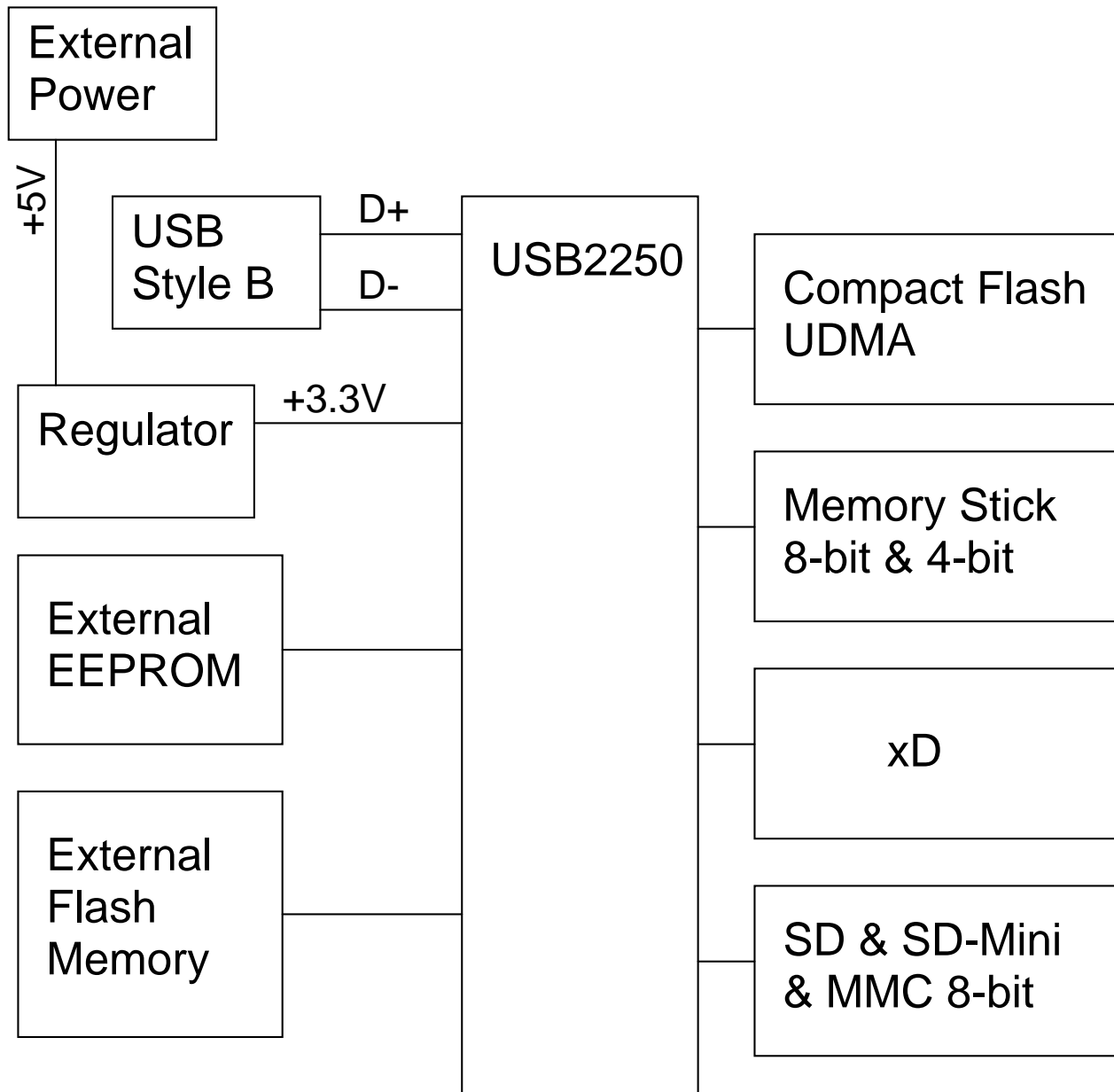

Revision History

Rev.	Date	Revision Summary	Author
01	20071211	Initial schematic from FDB-USB2250QFP128 (Antiope), Rev. A0	John Caras
02	20071212	Changed Power Caps, Updated Socket, Term Resistor bypass,	John Caras
03	20080103	BOM DNP passives, renamed nets, added serial port header.	John Caras
04	20080108	Added EMI Treatments	Carl Johnson
05	2008015	Revised per layout needs.	Carl Johnson
A	2008017	Renumbered and released.	Carl Johnson
A1	20080225	Swapped Pins 11 & 12 on the MS Connector J7. Swapped Card powers on R4 & R5. See the following rework documents: EVB-USB2250_A-RW_A1p0-CRD+PWR(cross-over).doc EVB-USB2250_A-RW_A1p1-D4-D5(cross-over).doc	John Caras
00B	20080320	Added Capacitors and Inductors for EMI. Removed Series Resistors. Consolidated schematic to 3 pages. Added optional industrial grade regulator.	John Caras
01B	20080408	Removed GND ferrite bead on xD, added beads to GND for CF, SD, MS.	Carl Johnson
B	20080409	Released.	Carl Johnson

 SMSC SUCCESS BY DESIGN		11000 N. Mopac Expressway Stonelake Building 6, Suite 500 Austin, TX 78759-5428 512.502.0070
Title: USB2250 Evaluation Board Document Number: EVB-USB2250		
Size: B	Project Name:	Nycteus
Date: Wednesday, April 09, 2008	Sheet 1 of 3	Rev B

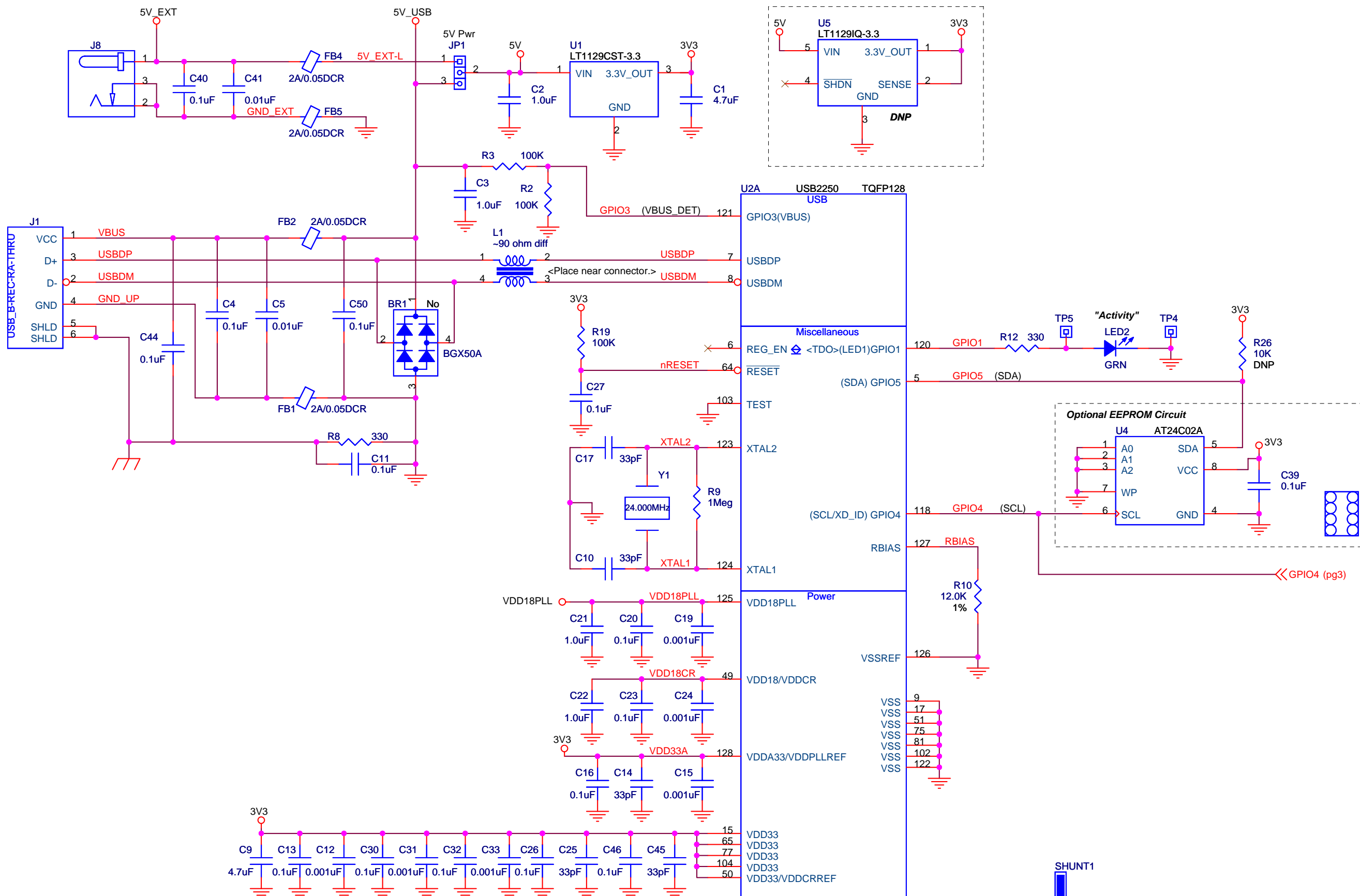

SHUNT1

*Note:
USB Zdiff = 90 Ohms

Zchar (typ)
1layer = 55 Ohms
2layer = 130 Ohms

		11000 N. Mopac Expressway Stonelake Building 6, Suite 500 Austin, TX 78759-5428 512.502.0070	
		Title: USB2250 Evaluation Board Document Number: EVB-USB2250	
Size: B	Project Name:	Nycteus Rev B	
Date: Wednesday, April 09, 2008	Sheet 2 of 3		

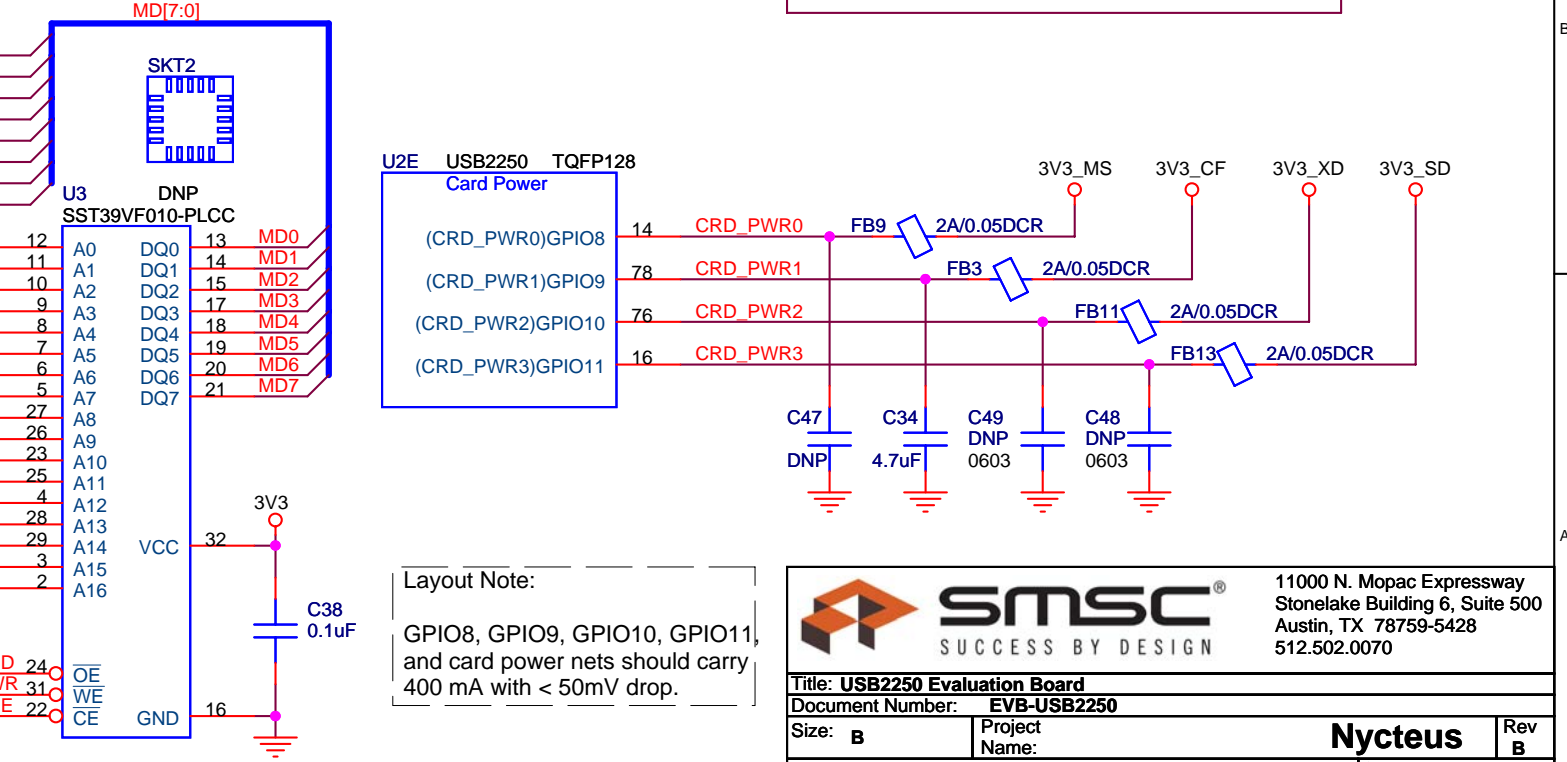
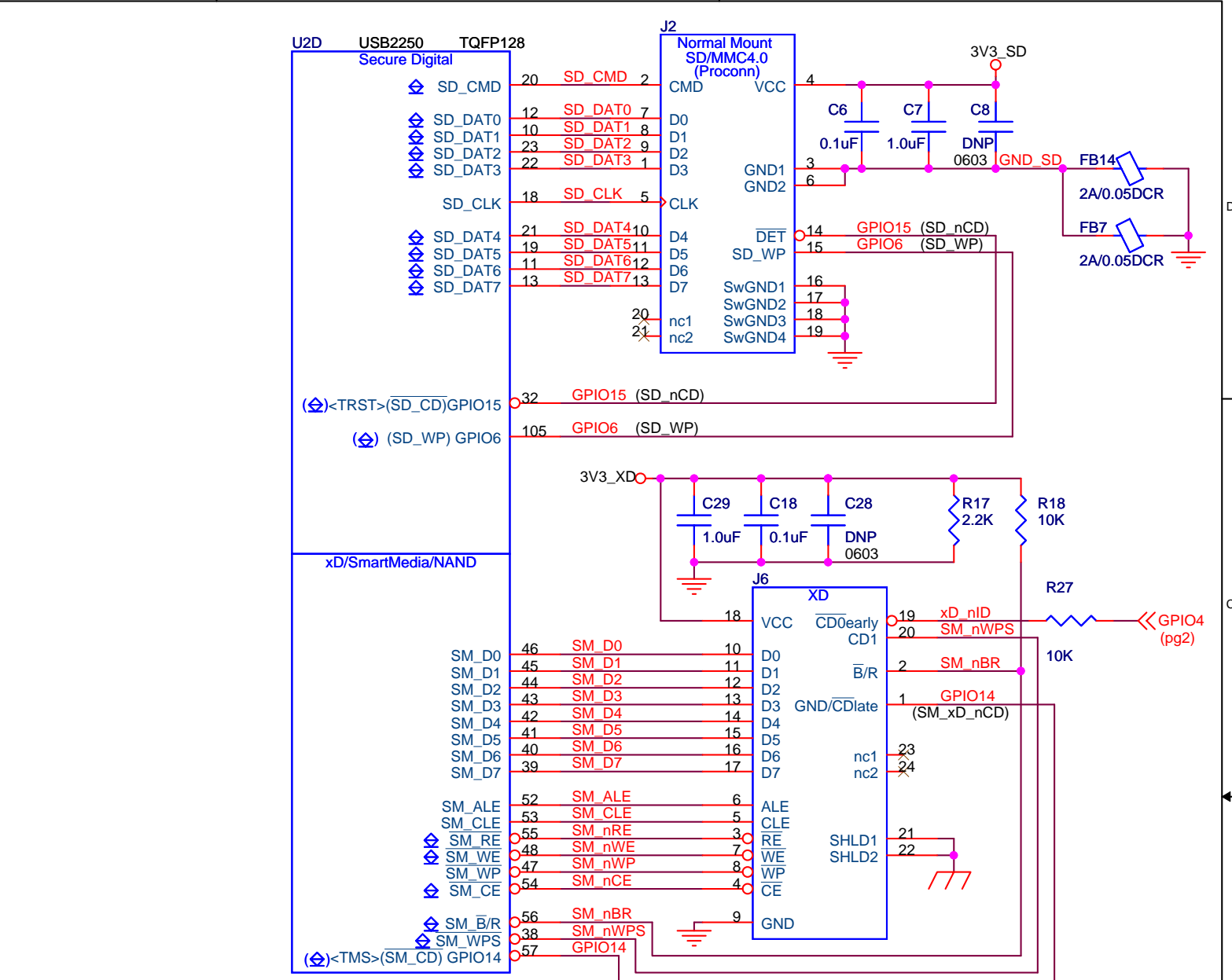
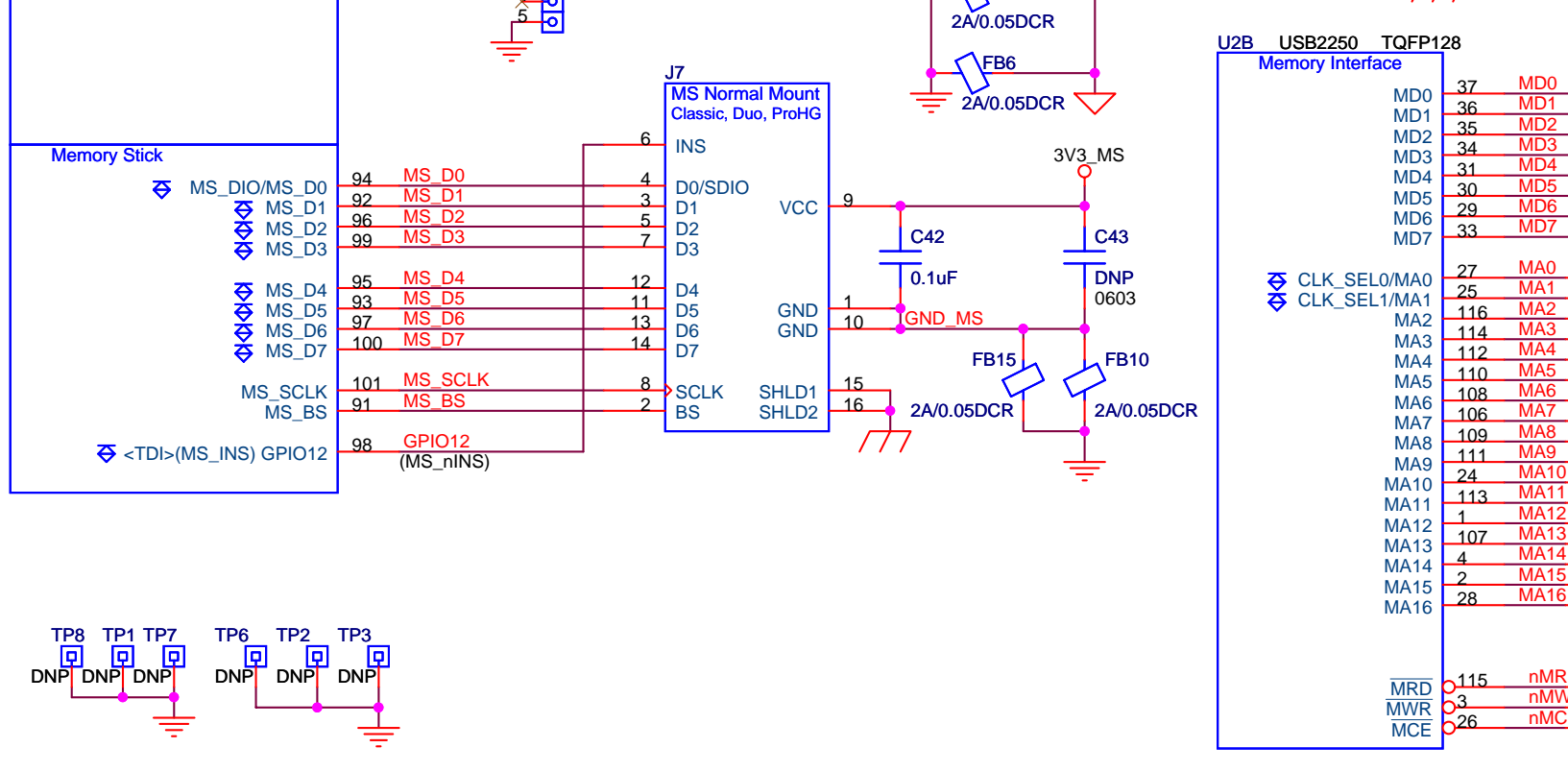
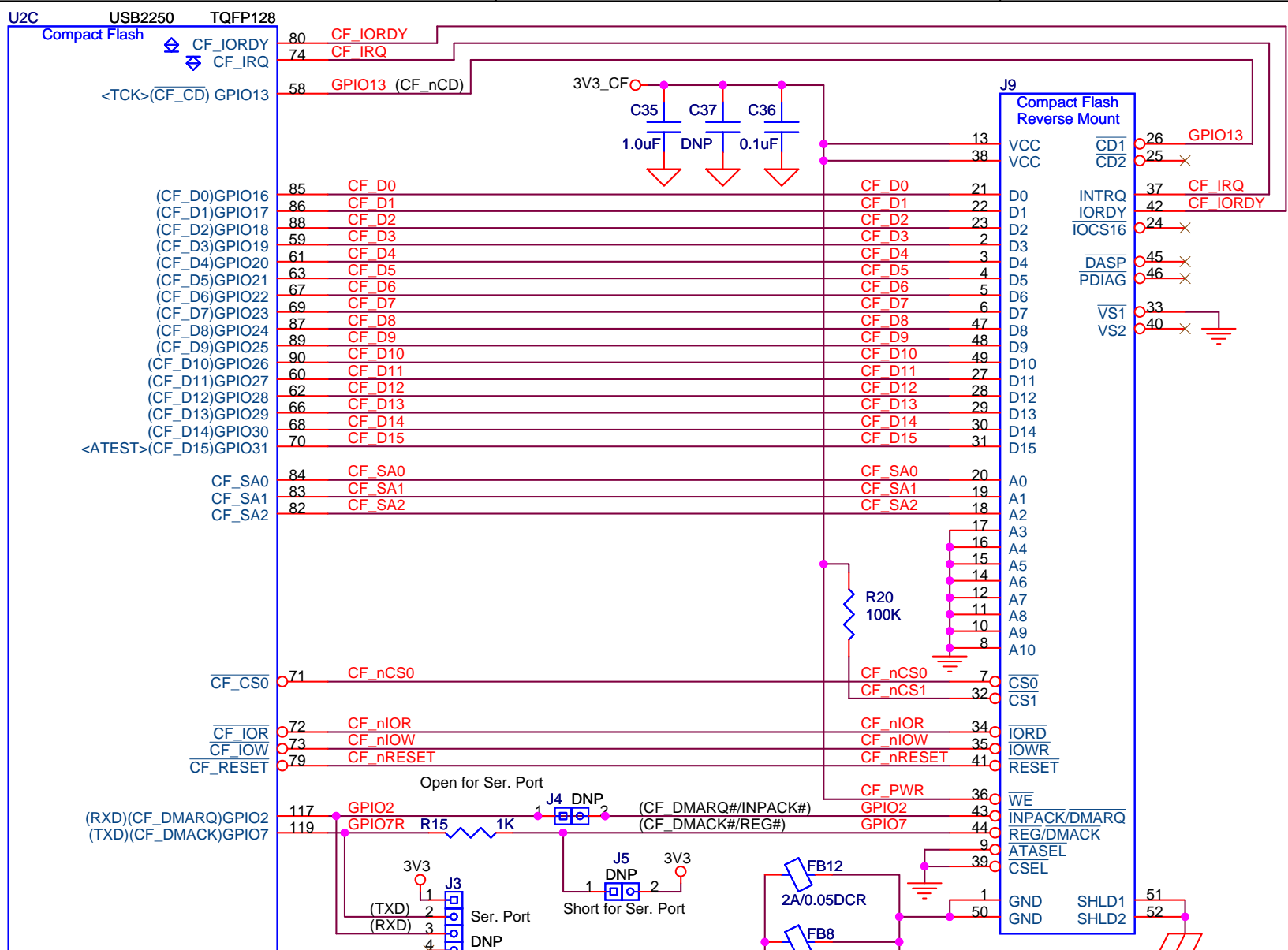

Layout Note:
GPIO8, GPIO9, GPIO10, GPIO11, and card power nets should carry 400 mA with < 50mV drop.

SMSC
SUCCESS BY DESIGN

11000 N. Mopac Expressway
Stonlake Building 6, Suite 500
Austin, TX 78759-5428
512.502.0070

Title: USB2250 Evaluation Board
Document Number: **EVB-USB2250**

Size: **B** Project Name: **Nycteus** Rev **B**

Date: **Wednesday, April 09, 2008** Sheet **3** of **3**