

# Revision History

Rev. 0.1 - 08/18/04 - Initial concept schematic.

Rev. A - 10/23/04 - Initial PCB layout

Rev. A1 - 10/26/04 - Changed two 0.1uF capacitors to 10uF, changed VBUS\_DETECT capacitor location, Added 3 pin header option for SELF\_PWR

 <b>SMSC</b> <sup>™</sup> SUCCESS BY DESIGN		11000 N. Mopac Expressway Stonelake Building 6, Suite 500 Austin, TX 78759-5428 512.502.0070
Title: EVB-USB2507Q		
Size: C	Document Number: EVB-USB2507Q	Rev: A1
Date: Tuesday, October 26, 2004 Sheet 1 of 3		

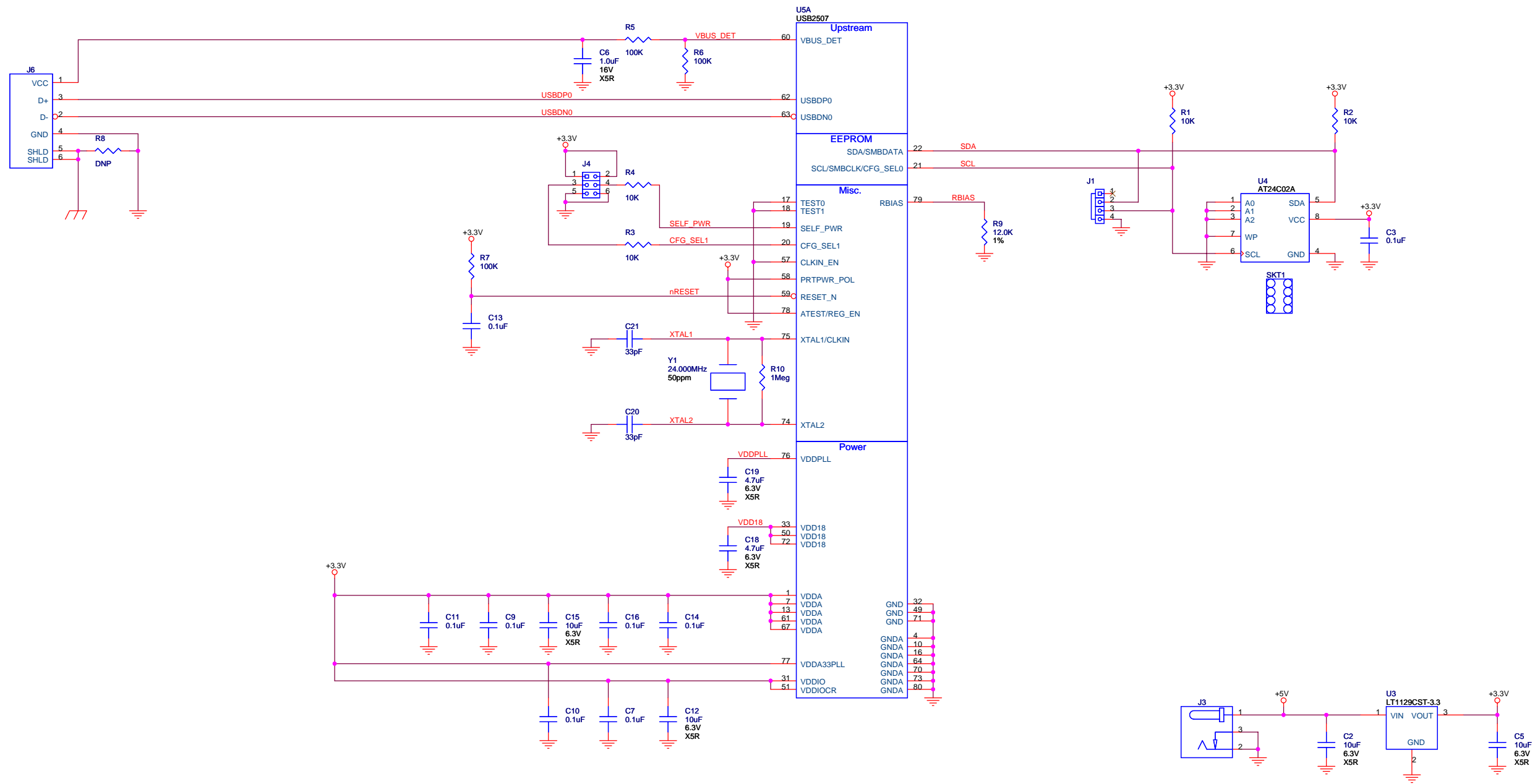

Title			EVB-USB2507Q		
Size	Document Number		Rev		
C	EVB-USB2507Q		A1		
Date:	Tuesday, October 26, 2004	Sheet	2	of	3

