



# USB224x/225x Family USB 2.0 Flash Media Card Controllers

Ultra Hi-Speed, Cost-effective, USB 2.0 Flash Media Card Controller Family for PC, Embedded and Consumer Applications

SMSC's USB224x/225x family of Hi-Speed USB 2.0 flash media card controllers provides an ultra-fast interface between a USB host controller and today's most popular flash media cards. Offering comprehensive USB 2.0 compliance and interoperability, the USB224x/225x product family is engineered to provide flexibility for system designers to choose independent or simultaneous access to a wide selection of flash media readers. It provides secure memory format options via external or internal memory, and is capable of high-performance throughput with new formats such as CF-Ultra Direct Memory Access (UDMA) and MS Pro-HG™.

The USB224x/225x consist of a USB 2.0 device transceiver, fast 8051 microprocessor and CompactFlash®(CF), MemoryStick™(MS), SmartMedia™(SM) and SecureDigital(SD) controllers in a single chip. SMSC's new ultra-fast card readers are well-suited for performance-intensive Microsoft® Windows Vista® applications such as ReadyBoost™. PC system performance can be improved by up to 10% when employing ReadyBoost with an SMSC flash media reader.\*

\* Results are based on actual measurements on evaluation platforms developed by SMSC, and are meant only as a general guideline, not as a guarantee. Actual customer results may vary based on a number of factors, including board layout and measurement technique.

## Highlights

- Optimized for Hi-Speed performance and versatility
- Supports SM/xD, MS/MS-Pro/MS-Pro-HG, MultiMediaCard (MMC)/SD and CF/CF-UDMA interfaces
- Capable of high-performance throughput > 35MB/s with new Hi-Speed formats – CF-UDMA, MS Pro-HG
- Well-suited for PC applications utilizing Microsoft ReadyBoost to improve system performance
- External or internal ROM option
- Secure memory format options supported via external or internal memory
- Supports individual or any combination of sockets
- Industrial-temp option - designed to meet -40° to 85°C requirements
- Optional, small footprint, 36-pin QFN package for single or fully-multiplexed card interface designs or space-constrained applications

## Target Applications

- Desktop/Notebook PCs
- Multi-function Printers
- Digital TVs
- Monitors
- Consumer Audio/Video Devices
- Stand-alone Flash Media Reader/Writers
- Digital Picture Frames
- Media Players
- Set-top Boxes
- Gaming Consoles
- Automobile/Home Audio Systems
- Industrial Applications

## Features and Benefits

FEATURES	BENEFITS
"Card Speed" Media Reader	Provides maximum throughput between flash media card and USB 2.0 interface to improve system performance
External or Internal ROM	Allows flexibility to create a secure memory format or to customize applications based on system requirements
ReadyBoost Support	Ultra-fast card is well-suited for Microsoft Windows Vista applications such as ReadyBoost to improve overall PC system performance
36-pin QFN package option	Very small footprint package for compact designs in individual or combination socket applications
Industrial temperature-rated -40° to 85°C	Designed to perform in rugged industrial environments

## Application Scenarios for SMSC's USB 2.0 Flash Media Card Controllers

- Provide individual or combinations of multiple format media card reader sockets on a PC, printer or embedded system
- Share music, video, still pictures or data files from a card reader to a notebook
- Print pictures to a photo printer or kiosk with a camera memory card
- Allow users to update system firmware to a PC or embedded application
- Software security keys can be stored in the media card as a hardware lock for select software programs
- Improve PC system performance with Windows Vista ReadyBoost feature and a media card

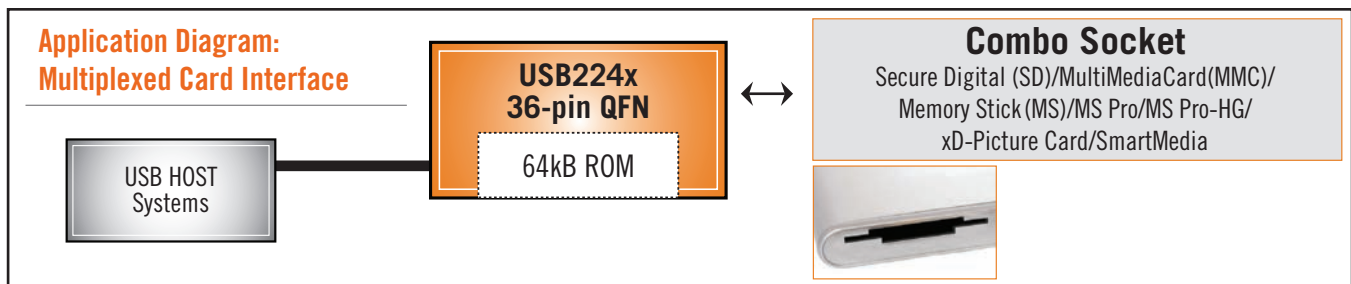
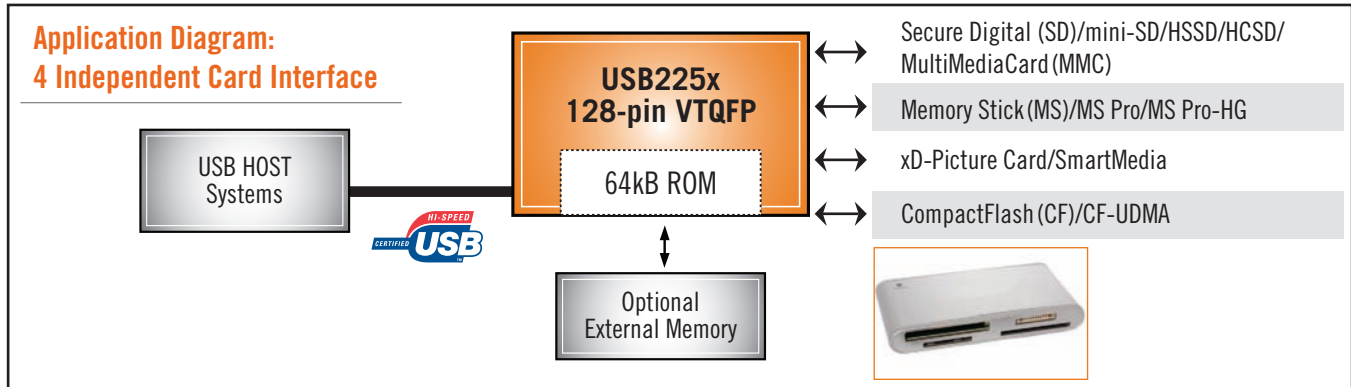

## Which USB224x/225x Family Member Is Right For Your Design?

	Package	SD/MMC	xD	MS/MS Pro/MS Pro-HG	CF/CF-UDMA	LUN	External Memory Interface	-40° to 85°C
USB2240	36-pin QFN	•	•	•		1		
USB2240i	36-pin QFN	•	•	•		1		•
USB2241	36-pin QFN	•		•		1		
USB2241i	36-pin QFN	•		•		1		•
USB2242	36-pin QFN			•		1		
USB2242i	36-pin QFN			•		1		•
USB2244	36-pin QFN	•				1		
USB2244i	36-pin QFN	•				1		•
USB2250	128-pin VTQFP	•	•	•	•	4	•	
USB2250i	128-pin VTQFP	•	•	•	•	4	•	•
USB2251	128-pin VTQFP	•		•	•	4	•	
USB2251i	128-pin VTQFP	•		•	•	4	•	•

Copyright ©2008 SMSC or its subsidiaries. All rights reserved. Although the information in this document has been checked and is believed to be accurate, no responsibility is assumed for inaccuracies. SMSC reserves the right to make changes to product descriptions and specifications at any time without notice. Contact your local SMSC sales office to obtain the latest specifications before placing your product order. The provision of this information does not convey any licenses under any patent rights or other intellectual property rights of SMSC or others. All sales are expressly conditional on your agreement to the terms and conditions of the most recently dated version of SMSC's standard Terms of Sale Agreement dated before the date of your order. Products may contain design defects or errors known as anomalies which may cause a product's functions to deviate from published specifications. Anomaly sheets are available upon request. SMSC products are not designed, intended, authorized or warranted for use in any life support or other application where product failure could cause or contribute to personal injury or severe property damage. Any and all such uses without prior written approval of an Officer of SMSC and further testing and/or modification will be fully at the risk of the customer. Copies of this document or other SMSC literature, as well as the Terms of Sale Agreement, may be obtained by visiting SMSC's website at <http://www.smsc.com>. SMSC and the SMSC logo are registered trademarks of Standard Microsystems Corporation ("SMSC"). Other names mentioned may be trademarks of their respective holders. All claims made herein speak as of the date of this material. The company does not undertake to update such statements. (05/08)