



**SMSC**<sup>®</sup>  
SUCCESS BY DESIGN

**LAN8700/LAN8700i**



## **±15kV ESD Protected MII/RMII 10/100 Ethernet Transceiver with HP Auto-MDIX Support and flexPWR<sup>®</sup> Technology in a Small Footprint**

### **PRODUCT FEATURES**

Data Brief

- Single-Chip Ethernet Physical Layer Transceiver (PHY)
- ESD Protection levels of ±8kV HBM without external protection devices
- ESD protection levels of IEC61000-4-2, ±8kV contact mode, and ±15kV for air discharge mode per independent test facility
- Comprehensive flexPWR<sup>®</sup> Technology
  - Flexible Power Management Architecture
- LVCMOS Variable I/O voltage range: +1.6V to +3.6V
- Integrated 3.3V to 1.8V regulator for optional single supply operation.
  - Regulator can be disabled if 1.8V system supply is available.
- Performs HP Auto-MDIX in accordance with IEEE 802.3ab specification
- Cable length greater than 150 meters
- Automatic Polarity Correction
- Latch-Up Performance Exceeds 150mA per EIA/JESD 78, Class II
- Energy Detect power-down mode
- Low Current consumption power down mode
- Low operating current consumption:
  - 39mA typical in 10BASE-T and
  - 79mA typical in 100BASE-TX mode
- Supports Auto-negotiation and Parallel Detection
- Supports the Media Independent Interface (MII) and Reduced Media Independent Interface (RMII)
- Compliant with IEEE 802.3-2005 standards
  - MII Pins tolerant to 3.6V
- IEEE 802.3-2005 compliant register functions
- Integrated DSP with Adaptive Equalizer
- Baseline Wander (BLW) Correction
- Vendor Specific register functions
- Low profile 36-pin QFN lead-free RoHS compliant package (6 x 6 x 0.9mm height)
- 4 LED status indicators
- Commercial Operating Temperature 0° C to 70° C
- Industrial Operating Temperature -40° C to 85° C version available (LAN8700i)

### **Applications**

- Set Top Boxes
- Network Printers and Servers
- LAN on Motherboard
- 10/100 PCMCIA/CardBus Applications
- Embedded Telecom Applications
- Video Record/Playback Systems
- Cable Modems/Routers
- DSL Modems/Routers
- Digital Video Recorders
- Personal Video Recorders
- IP and Video Phones
- Wireless Access Points
- Digital Televisions
- Digital Media Adaptors/Servers
- POS Terminals
- Automotive Networking
- Gaming Consoles
- Security Systems
- POE Applications
- Access Control

**Order Numbers:****LAN8700C-AEZG for 36-pin, QFN lead-free RoHS compliant package****LAN8700iC-AEZG for (Industrial Temp) 36-pin, QFN lead-free RoHS compliant package**

4900 pcs per tray

**LAN8700C-AEZG-TR for 36-pin, QFN lead-free RoHS compliant package (tape and reel)**

3000 pcs per reel

**This product meets the halogen maximum concentration values per IEC61249-2-21****For RoHS compliance and environmental information, please visit [www.smSC.com/rohs](http://www.smSC.com/rohs)**

80 ARKAY DRIVE, HAUPPAUGE, NY 11788 (631) 435-6000, FAX (631) 273-3123

Copyright © 2009 SMSC or its subsidiaries. All rights reserved.

Circuit diagrams and other information relating to SMSC products are included as a means of illustrating typical applications. Consequently, complete information sufficient for construction purposes is not necessarily given. Although the information has been checked and is believed to be accurate, no responsibility is assumed for inaccuracies. SMSC reserves the right to make changes to specifications and product descriptions at any time without notice. Contact your local SMSC sales office to obtain the latest specifications before placing your product order. The provision of this information does not convey to the purchaser of the described semiconductor devices any licenses under any patent rights or other intellectual property rights of SMSC or others. All sales are expressly conditional on your agreement to the terms and conditions of the most recently dated version of SMSC's standard Terms of Sale Agreement dated before the date of your order (the "Terms of Sale Agreement"). The product may contain design defects or errors known as anomalies which may cause the product's functions to deviate from published specifications. Anomaly sheets are available upon request. SMSC products are not designed, intended, authorized or warranted for use in any life support or other application where product failure could cause or contribute to personal injury or severe property damage. Any and all such uses without prior written approval of an Officer of SMSC and further testing and/or modification will be fully at the risk of the customer. Copies of this document or other SMSC literature, as well as the Terms of Sale Agreement, may be obtained by visiting SMSC's website at <http://www.smSC.com>. SMSC is a registered trademark of Standard Microsystems Corporation ("SMSC"). Product names and company names are the trademarks of their respective holders.

**SMSC DISCLAIMS AND EXCLUDES ANY AND ALL WARRANTIES, INCLUDING WITHOUT LIMITATION ANY AND ALL IMPLIED WARRANTIES OF MERCHANTABILITY, FITNESS FOR A PARTICULAR PURPOSE, TITLE, AND AGAINST INFRINGEMENT AND THE LIKE, AND ANY AND ALL WARRANTIES ARISING FROM ANY COURSE OF DEALING OR USAGE OF TRADE. IN NO EVENT SHALL SMSC BE LIABLE FOR ANY DIRECT, INCIDENTAL, INDIRECT, SPECIAL, PUNITIVE, OR CONSEQUENTIAL DAMAGES; OR FOR LOST DATA, PROFITS, SAVINGS OR REVENUES OF ANY KIND; REGARDLESS OF THE FORM OF ACTION, WHETHER BASED ON CONTRACT; TORT; NEGLIGENCE OF SMSC OR OTHERS; STRICT LIABILITY; BREACH OF WARRANTY; OR OTHERWISE; WHETHER OR NOT ANY REMEDY OF BUYER IS HELD TO HAVE FAILED OF ITS ESSENTIAL PURPOSE, AND WHETHER OR NOT SMSC HAS BEEN ADVISED OF THE POSSIBILITY OF SUCH DAMAGES.**

## General Description

The SMSC LAN8700/LAN8700i is a low-power, industrial temperature (LAN8700i), variable I/O voltage, analog interface IC with HP Auto-MDIX support for high-performance embedded Ethernet applications. The LAN8700/LAN8700i can be configured to operate on a single 3.3V supply utilizing an integrated 3.3V to 1.8V linear regulator. An option is available to disable the linear regulator to optimize system designs that have a 1.8V power plane available.

### 0.1 Architectural Overview

The LAN8700/LAN8700i consists of an encoder/decoder, scrambler/descrambler, wave-shaping transmitter, output driver, twisted-pair receiver with adaptive equalizer and baseline wander (BLW) correction, and clock and data recovery functions. The LAN8700/LAN8700i can be configured to support either the Media Independent Interface (MII) or the Reduced Media Independent Interface (RMII).

The LAN8700/LAN8700i is compliant with IEEE 802.3-2005 standards (MII Pins tolerant to 3.6V) and supports both IEEE 802.3-2005 compliant and vendor-specific register functions. It contains a full-duplex 10-BASE-T/100BASE-TX transceiver and supports 10-Mbps (10BASE-T) operation on Category 3 and Category 5 unshielded twisted-pair cable, and 100-Mbps (100BASE-TX) operation on Category 5 unshielded twisted-pair cable.

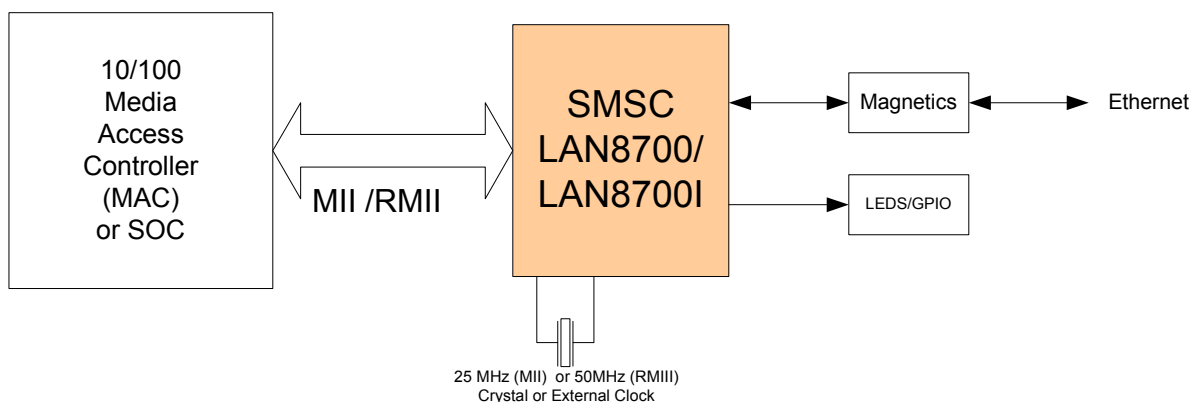

**Figure 1 LAN8700/LAN8700i System Block Diagram**

Hubs and switches with multiple integrated MACs and external PHYs can have a large pin count due to the high number of pins needed for each MII interface. An increasing pin count causes increasing cost.

The RMII interface is intended for use on Switch based ASICs or other embedded solutions requiring minimal pincount for ethernet connectivity. RMII requires only 6 pins for each MAC to PHY interface plus one common reference clock. The MII requires 16 pins for each MAC to PHY interface.

The SMSC LAN8700/LAN8700i is capable of running in RMII mode. Please contact your SMSC sales representative for the latest RMII specification.

The LAN8700/LAN8700i referenced throughout this document applies to both the commercial temperature and industrial temperature components. The LAN8700i refers to only the industrial temperature component.

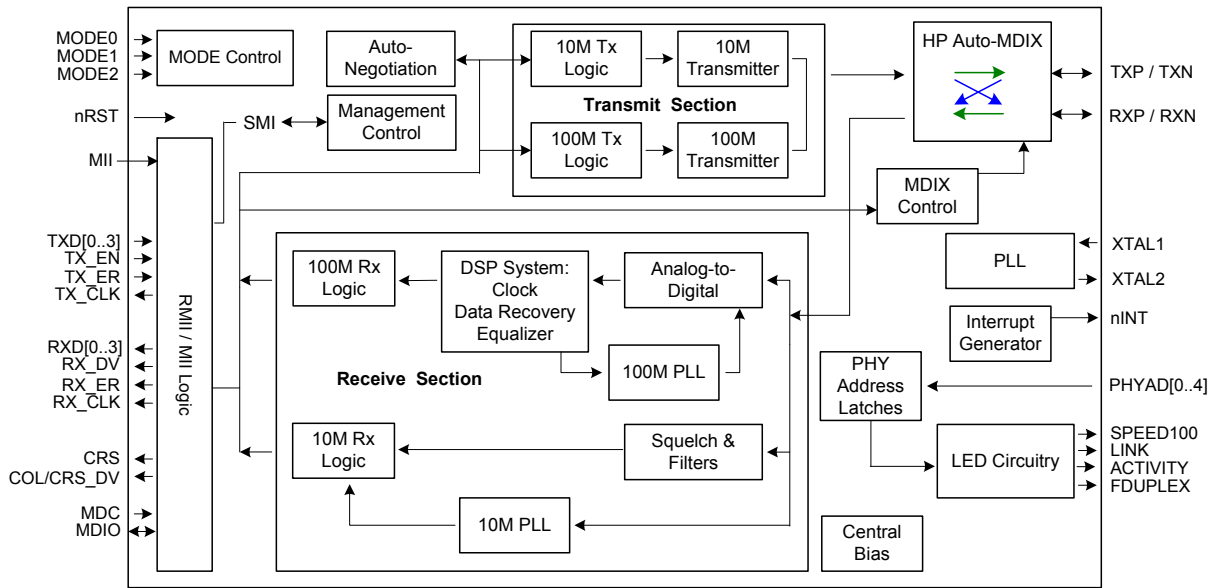

**Figure 2 LAN8700/LAN8700i Architectural Overview**

# Pin Diagram

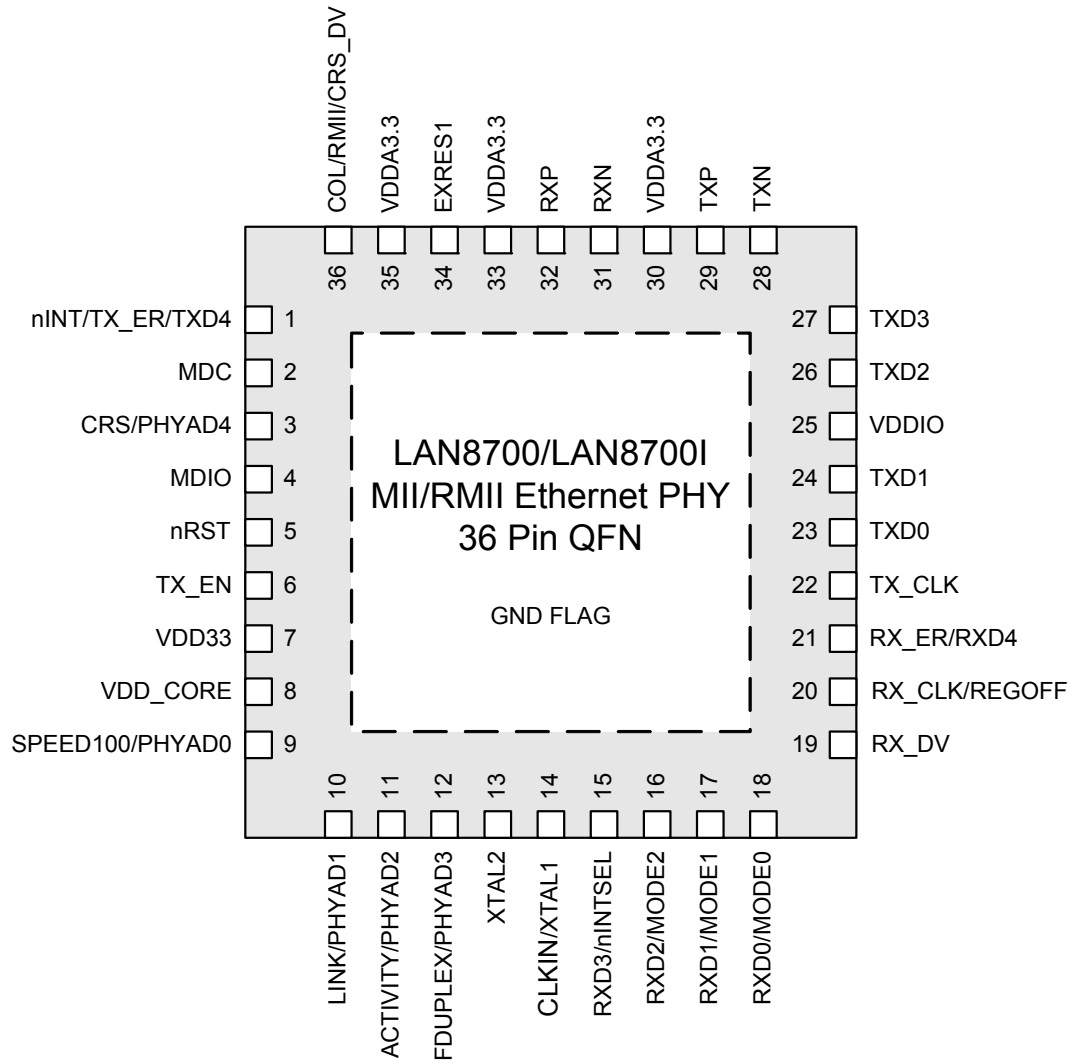

Figure 3 LAN8700/LAN8700i Package Pin Diagram (Top View)

**Table 1 LAN8700/LAN8700i 36-PIN QFN Pinout**

| <b>PIN NO.</b> | <b>PIN NAME</b> | <b>PIN NO.</b> | <b>PIN NAME</b> |
|----------------|-----------------|----------------|-----------------|
| 1              | nINT/TX_ER/TXD4 | 19             | RX_DV           |
| 2              | MDC             | 20             | RX_CLK/REGOFF   |
| 3              | CRS/PHYAD4      | 21             | RX_ER/RXD4      |
| 4              | MDIO            | 22             | TXCLK           |
| 5              | nRST            | 23             | TXD0            |
| 6              | TX_EN           | 24             | TXD1            |
| 7              | VDD33           | 25             | VDDIO           |
| 8              | VDD_CORE        | 26             | TXD2            |
| 9              | SPEED100/PHYAD0 | 27             | TXD3            |
| 10             | LINK/PHYAD1     | 28             | TXN             |
| 11             | ACTIVITY/PHYAD2 | 29             | TXP             |
| 12             | FDUPLEX/PHYAD3  | 30             | VDDA3.3         |
| 13             | XTAL2           | 31             | RXN             |
| 14             | CLKIN/XTAL1     | 32             | RXP             |
| 15             | RXD3/nINTSEL    | 33             | VDDA3.3         |
| 16             | RXD2/MODE2      | 34             | EXRES1          |
| 17             | RXD1/MODE1      | 35             | VDDA3.3         |
| 18             | RXD0/MODE0      | 36             | COL/MII/CRS_DV  |

## Pin Description

This section describes the signals on each pin. When a lower case “n” is used at the beginning of the signal name, it indicates that the signal is active low. For example, nRST indicates that the reset signal is active low.

### I/O Signals

- I Input. Digital LVCMOS levels.
- O Output. Digital LVCMOS levels.
- I/O Input or Output. Digital LVCMOS levels.

**Note:** The digital signals are not 5V tolerant. They are variable voltage from +1.6V to +3.6V.

AI Input. Analog levels.

AO Output. Analog levels.

**Table 2 MII Signals**

| SIGNAL NAME             | TYPE | DESCRIPTION   |
|-------------------------|------|---|
| TXD0                    | I    | <b>Transmit Data 0:</b> Bit 0 of the 4 data bits that are accepted by the PHY for transmission.   |
| TXD1                    | I    | <b>Transmit Data 1:</b> Bit 1 of the 4 data bits that are accepted by the PHY for transmission.   |
| TXD2                    | I    | <b>Transmit Data 2:</b> Bit 2 of the 4 data bits that are accepted by the PHY for transmission<br><b>Note:</b> This signal should be grounded in RMII Mode.   |
| TXD3                    | I    | <b>Transmit Data 3:</b> Bit 3 of the 4 data bits that are accepted by the PHY for transmission.<br><b>Note:</b> This signal should be grounded in RMII Mode   |
| nINT/<br>TX_ER/<br>TXD4 | I/O  | <b>MII Transmit Error:</b> When driven high, the 4B/5B encode process substitutes the Transmit Error code-group (/H/) for the encoded data word. This input is ignored in 10Base-T operation.<br><br><b>MII Transmit Data 4:</b> In Symbol Interface (5B Decoding) mode, this signal becomes the MII Transmit Data 4 line, the MSB of the 5-bit symbol code-group.<br><br><b>Notes:</b> <ul style="list-style-type: none"> <li>■ This signal is not used in RMII Mode.</li> <li>■ This signal is mux'd with nINT</li> </ul> |
| TX_EN                   | I    | <b>Transmit Enable:</b> Indicates that valid data is presented on the TXD[3:0] signals, for transmission. In RMII Mode, only TXD[1:0] have valid data.  |
| TX_CLK                  | O    | <b>Transmit Clock:</b> 25MHz in 100Base-TX mode. 2.5MHz in 10Base-T mode.<br><b>Note:</b> This signal is not used in RMII Mode  |
| RXD0/<br>MODE0          | I/O  | <b>Receive Data 0:</b> Bit 0 of the 4 data bits that are sent by the PHY in the receive path.<br><br><b>PHY Operating Mode Bit 0:</b> set the default MODE of the PHY.  |

**Table 2 MII Signals (continued)**

| SIGNAL NAME       | TYPE | DESCRIPTION   |
|-------------------|------|---|
| RXD1/<br>MODE1    | I/O  | <p><b>Receive Data 1:</b> Bit 1 of the 4 data bits that are sent by the PHY in the receive path.</p> <p><b>PHY Operating Mode Bit 1:</b> set the default MODE of the PHY.</p>   |
| RXD2/<br>MODE2    | I/O  | <p><b>Receive Data 2:</b> Bit 2 of the 4 data bits that are sent by the PHY in the receive path.</p> <p><b>PHY Operating Mode Bit 2:</b> set the default MODE of the PHY.</p> <p><b>Notes:</b></p> <ul style="list-style-type: none"> <li>■ RXD2 is not used in RMII Mode.</li> </ul>   |
| RXD3/<br>nINTSEL  | I/O  | <p><b>Receive Data 3:</b> Bit 3 of the 4 data bits that are sent by the PHY in the receive path.</p> <p><b>nINTSEL:</b> On power-up or external reset, the mode of the nINT/TXER/TXD4 pin is selected.</p> <ul style="list-style-type: none"> <li>■ When RXD3/nINTSEL is floated or pulled to VDDIO, nINT is selected for operation on pin nINT/TXER/TXD4 (default).</li> <li>■ When RXD3/nINTSEL is pulled low to VSS through a resistor, TXER/TXD4 is selected for operation on pin nINT/TXER/TXD4.</li> </ul> <p><b>Notes:</b></p> <ul style="list-style-type: none"> <li>■ RXD3 is not used in RMII Mode</li> <li>■ If the nINT/TXER/TXD4 pin is configured for nINT mode, then a pull-up resistor is needed to VDDIO on the nINT/TXER/TXD4 pin.</li> </ul> |
| RX_ER/<br>RXD4/   | O    | <p><b>Receive Error:</b> Asserted to indicate that an error was detected somewhere in the frame presently being transferred from the PHY.</p> <p><b>MII Receive Data 4:</b> In Symbol Interface (5B Decoding) mode, this signal is the MII Receive Data 4 signal, the MSB of the received 5-bit symbol code-group. Unless configured in this mode, the pin functions as RX_ER.</p> <p><b>Note:</b> This pin has an internal pull-down resistor, and must not be high during reset. The RX_ER signal is optional in RMII Mode.</p>   |
| RX_DV             | O    | <p><b>Receive Data Valid:</b> Indicates that recovered and decoded data nibbles are being presented on RXD[3:0].</p> <p><b>Note:</b> This pin has an internal pull-down resistor, and must not be high during reset. This signal is not used in RMII Mode.</p>  |
| RX_CLK/<br>REGOFF | I/O  | <p><b>Receive Clock:</b> In MII mode, this pin is the receive clock output. 25MHz in 100Base-TX mode. 2.5MHz in 10Base-T mode.</p> <p><b>Note:</b> This signal is not used in RMII Mode.</p> <p><b>Regulator Off:</b> This pin may be used to configure the internal 1.8V regulator off. This pin is sampled during the power-on sequence to determine if the internal regulator should turn on. When the regulator is disabled, external 1.8V must be supplied to VDD_CORE, and the voltage at VDD33 must be at least 2.64V before voltage is applied to VDD_CORE.</p>   |



Table 2 MII Signals (continued)

| SIGNAL NAME             | TYPE | DESCRIPTION   |
|-------------------------|------|---|
| COL/<br>RMII/<br>CRS_DV | I/O  | <p><b>MII Mode Collision Detect:</b> Asserted to indicate detection of collision condition.</p> <p><b>RMII – MII/RMII mode selection</b> is latched on the rising edge of the internal reset (nreset) based on the following strapping:</p> <ul style="list-style-type: none"> <li>Float this pin for MII mode or pull-high with an external resistor to VDDIO to set the device in RMII mode.</li> </ul> <p><b>RMII Mode CRS_DV (Carrier Sense/Receive Data Valid)</b><br/>Asserted to indicate when the receive medium is non-idle. When a 10BT packet is received, CRS_DV is asserted, but RXD[1:0] is held low until the SFD byte (10101011) is received. In 10BT, half-duplex mode, transmitted data is not looped back onto the receive data pins, per the RMII standard.</p> |
| CRS/<br>PHYAD4          | I/O  | <p><b>Carrier Sense:</b> Indicates detection of carrier.</p> <p><b>Note:</b> This signal is mux'd with PHYAD4</p>   |

Table 3 LED Signals

| SIGNAL NAME         | TYPE | DESCRIPTION   |
|---------------------|------|---|
| SPEED100/<br>PHYAD0 | I/O  | <p><b>LED1 – SPEED100</b> indication. Active indicates that the selected speed is 100Mbps. Inactive indicates that the selected speed is 10Mbps.</p> <p><b>Note:</b> This signal is mux'd with PHYAD0</p> |
| LINK/<br>PHYAD1     | I/O  | <p><b>LED2 – LINK ON</b> indication. Active indicates that the Link (100Base-TX or 10Base-T) is on.</p> <p><b>Note:</b> This signal is mux'd with PHYAD1</p>  |
| ACTIVITY/<br>PHYAD2 | I/O  | <p><b>LED3 – ACTIVITY</b> indication. Active indicates that there is Carrier sense (CRS) from the active PMD.</p> <p><b>Note:</b> This signal is mux'd with PHYAD2</p>                                    |
| FDUPLEX/<br>PHYAD3  | I/O  | <p><b>LED4 – DUPLEX</b> indication. Active indicates that the PHY is in full-duplex mode.</p> <p><b>Note:</b> This signal is mux'd with PHYAD3</p>  |

Table 4 Management Signals

| SIGNAL NAME | TYPE | DESCRIPTION   |
|-------------|------|---|
| MDIO        | I/O  | <b>Management Data Input/OUTPUT:</b> Serial management data input/output. |
| MDC         | I    | <b>Management Clock:</b> Serial management clock.                         |

**Table 5 Boot Strap Configuration Inputs (Note 1)**

| SIGNAL NAME             | TYPE | DESCRIPTION   |
|-------------------------|------|---|
| CRS/<br>PHYAD4          | I/O  | <b>PHY Address Bit 4:</b> set the default address of the PHY. This signal is mux'd with CRS<br><b>Note:</b> This signal is mux'd with CRS   |
| FDUPLEX/<br>PHYAD3      | I/O  | <b>PHY Address Bit 3:</b> set the default address of the PHY.<br><b>Note:</b> This signal is mux'd with FDUPLEX   |
| ACTIVITY/<br>PHYAD2     | I/O  | <b>PHY Address Bit 2:</b> set the default address of the PHY.<br><b>Note:</b> This signal is mux'd with ACTIVITY  |
| LINK/<br>PHYAD1         | I/O  | <b>PHY Address Bit 1:</b> set the default address of the PHY.<br><b>Note:</b> This signal is mux'd with LINK  |
| SPEED100/<br>PHYAD0     | I/O  | <b>PHY Address Bit 0:</b> set the default address of the PHY.<br><b>Note:</b> This signal is mux'd with SPEED100  |
| RXD2/<br>MODE2          | I/O  | <b>PHY Operating Mode Bit 2:</b> set the default MODE of the PHY.<br><b>Note:</b> This signal is mux'd with RXD2  |
| RXD1/<br>MODE1          | I/O  | <b>PHY Operating Mode Bit 1:</b> set the default MODE of the PHY.<br><b>Note:</b> This signal is mux'd with RXD1  |
| RXD0/<br>MODE0          | I/O  | <b>PHY Operating Mode Bit 0:</b> set the default MODE of the PHY.<br><b>Note:</b> This signal is mux'd with RXD0  |
| RX_CLK/<br>REGOFF       | I/O  | <b>Internal Regulator off:</b> disable the internal +1.8v regulator. This signal is mux'd with RX_CLK.<br><ul style="list-style-type: none"> <li>■ Float to enable the internal +1.8v regulator.</li> <li>■ Pull up with a resistor to VDDIO to disable the internal regulator.</li> </ul>  |
| COL/<br>RMII/<br>CRS_DV | I/O  | <b>Digital Communication Mode:</b> set the digital communications mode of the PHY to RMII or MII. This signal is muxed with the Collision signal (MII mode) and Carrier Sense/ receive Data Valid (RMII mode)<br><ul style="list-style-type: none"> <li>■ Float for MII mode.</li> <li>■ Pull up with a resistor to VDDIO for RMII mode.</li> </ul>   |
| RXD3/<br>nINTSEL        | I/O  | <b>nINT pin mode select:</b> set the mode of pin 1.<br><ul style="list-style-type: none"> <li>■ Default, left floating pin 1 is nINT, active low interrupt output.</li> </ul> <b>Note:</b> For nINT mode, tie nINT/TXD4/TXER to VDDIO with a resistor.<br><ul style="list-style-type: none"> <li>■ Pulled to VSS by a resistor, pin 1 is TX_ER/TXD4, Transmit Error or Transmit data 4 (5B mode).</li> </ul> <b>Note:</b> For TXD4/TXER mode, do not tie nINT/TXD4/TXER to VDDIO or Ground. |

**Note 1** On nRST transition high, the PHY latches the state of the configuration pins in this table.



Table 6 General Signals

| SIGNAL NAME             | TYPE | DESCRIPTION  |
|-------------------------|------|--|
| nINT/<br>TX_ER/<br>TXD4 | I/O  | <b>LAN Interrupt</b> – Active Low output. Place an external resistor pull-up to VCC 3.3V.<br><b>Note:</b> This signal is mux'd with TXER/TXD4  |
| nRST                    | I    | <b>External Reset</b> – input of the system reset. This signal is active LOW.  |
| CLKIN/<br>XTAL1         | I/O  | <b>Clock Input</b> – 25 Mhz or 50 MHz external clock or crystal input.<br>In MII mode, this signal is the 25 MHz reference input clock<br>In RMII mode, this signal is the 50 MHz reference input clock which is typically also driven to the RMII compliant Ethernet MAC clock input. |
| XTAL2                   | O    | <b>Clock Output</b> – 25 MHz crystal output.<br><b>Note:</b> Float this pin if using an external clock being driven through CLKIN/XTAL1  |

Table 7 10/100 Line Interface

| SIGNAL NAME | TYPE | DESCRIPTION   |
|-------------|------|---|
| TXP         | AO   | <b>Transmit Data Positive:</b> 100Base-TX or 10Base-T differential transmit outputs to magnetics. |
| TXN         | AO   | <b>Transmit Data Negative:</b> 100Base-TX or 10Base-T differential transmit outputs to magnetics. |
| RXP         | AI   | <b>Receive Data Positive:</b> 100Base-TX or 10Base-T differential receive inputs from magnetics.  |
| RXN         | AI   | <b>Receive Data Negative:</b> 100Base-TX or 10Base-T differential receive inputs from magnetics.  |

Table 8 Analog References

| SIGNAL NAME | TYPE | DESCRIPTION   |
|-------------|------|---|
| EXRES1      | AI   | Connects to reference resistor of value 12.4K-Ohm, 1% connected as described in the Analog Layout Guidelines. |

Table 9 Power Signals

| SIGNAL NAME | TYPE  | DESCRIPTION                           |
|-------------|-------|---------------------------------------|
| VDDIO       | POWER | +1.6V to +3.6V Variable I/O Pad Power |
| VDD33       | POWER | +3.3V Core Regulator Input.           |
| VDDA3.3     | POWER | +3.3V Analog Power                    |

**Table 9 Power Signals (continued)**

| SIGNAL NAME | TYPE  | DESCRIPTION  |
|-------------|-------|--|
| VDD_CORE    | POWER | +1.8V (Core voltage) - 1.8V for digital circuitry on chip. Supplied by the on-chip regulator unless configured for regulator off mode using the RX_CLK/REGOFF pin. Place a 0.1uF capacitor near this pin and connect the capacitor from this pin to ground. When using the on-chip regulator, place a 4.7uF ±20% capacitor with ESR < 1ohm near this pin and connect the capacitor from this pin to ground. X5R or X7R ceramic capacitors are recommended since they exhibit an ESR lower than 0.1ohm at frequencies greater than 10kHz. |
| VSS         | POWER | Exposed Ground Flag. The flag must be connected to the ground plane with an array of vias as described in the Analog Layout Guidelines   |

# Package Outline

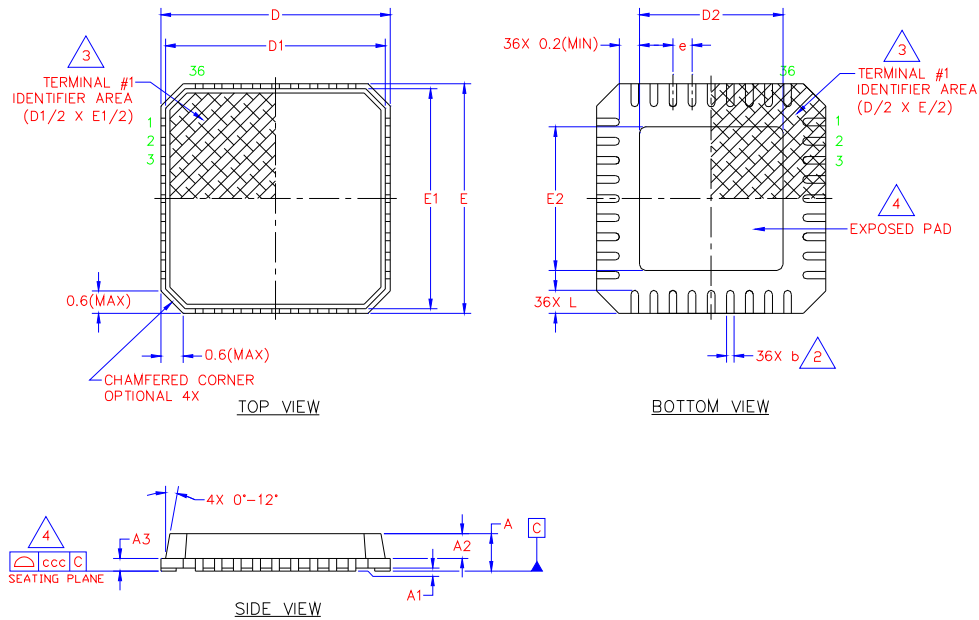

Figure 4 36-Pin QFN Package Outline, 6 x 6 x 0.90 mm Body (Lead-Free)

Table 10 36-Pin QFN Package Parameters

|     | MIN        | NOMINAL | MAX  | REMARKS                     |
|-----|------------|---------|------|-----------------------------|
| A   | 0.80       | ~       | 1.00 | Overall Package Height      |
| A1  | 0          | ~       | 0.05 | Standoff                    |
| A2  | 0.60       | ~       | 0.80 | Mold Thickness              |
| A3  | 0.20 REF   |         |      | Copper Lead-frame Substrate |
| D   | 5.85       | ~       | 6.15 | X Overall Size              |
| D1  | 5.55       | ~       | 5.95 | X Mold Cap Size             |
| D2  | 3.55       | ~       | 3.85 | X exposed Pad Size          |
| E   | 5.85       | ~       | 6.15 | Y Overall Size              |
| E1  | 5.55       | ~       | 5.95 | Y Mold Cap Size             |
| E2  | 3.55       | ~       | 3.85 | Y exposed Pad Size          |
| L   | 0.35       | ~       | 0.75 | Terminal Length             |
| e   | 0.50 Basic |         |      | Terminal Pitch              |
| b   | 0.18       | ~       | 0.30 | Terminal Width              |
| ccc | ~          | ~       | 0.08 | Coplanarity                 |

**Notes:**

- Controlling Unit: millimeter.
- Dimension b applies to plated terminals and is measured between 0.15mm and 0.30mm from the terminal tip. Tolerance on the true position of the terminal is ± 0.05 mm at maximum material conditions (MMC).
- Details of terminal #1 identifier are optional but must be located within the zone indicated.
- Coplanarity zone applies to exposed pad and terminals.